

Adventurer Campervan Air Flow 12V Roof Vent with Fan - LED Lights

Instructions on Installation and Use

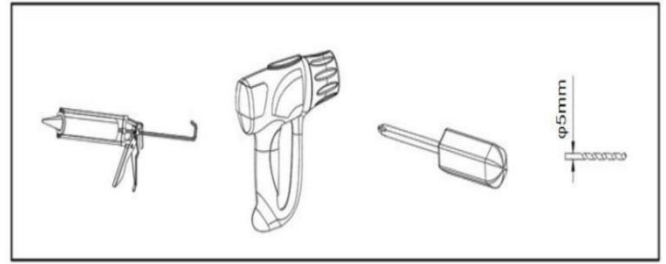

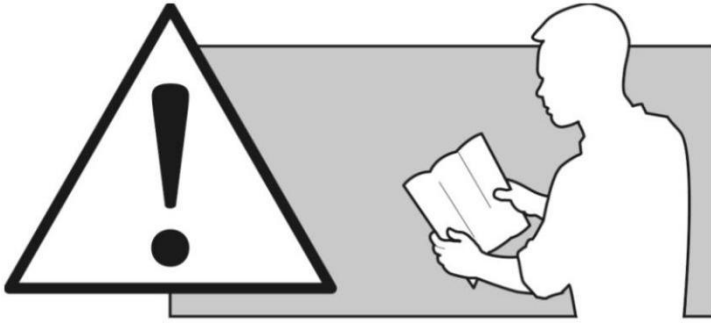

I. Specifications

Voltage (V)	12V
Current (A)	2.7A ± 10%
Power (W)	32W
Airflow (CFM)	3000CFM
Maximum opening angle (°)	≤ 11°
Dimensions (mm)	622*520*520mm
Height above vehicle roof	113 ± 2mm
Compatible wall board thickness	25-150mm

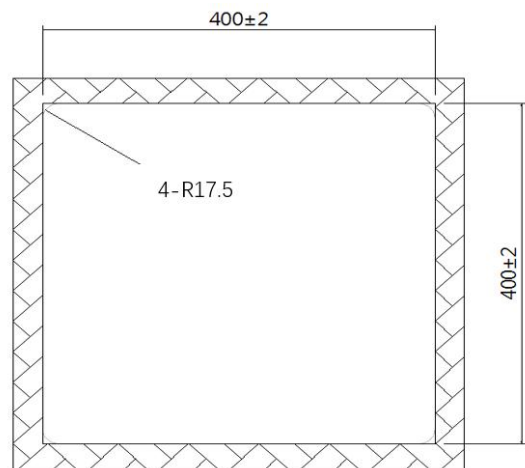

Cut-out Size

II. Installation Steps

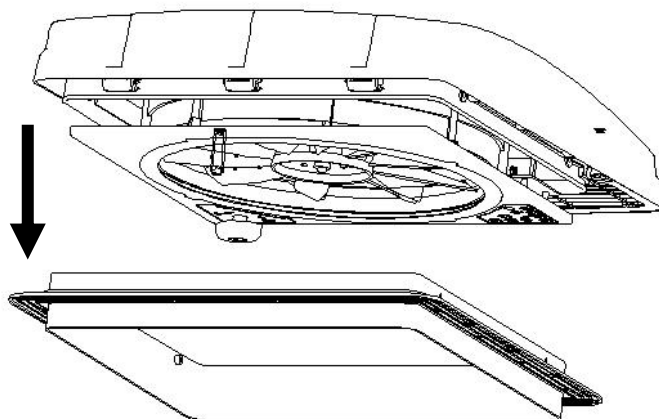

Step 1: Separate frame from main unit.

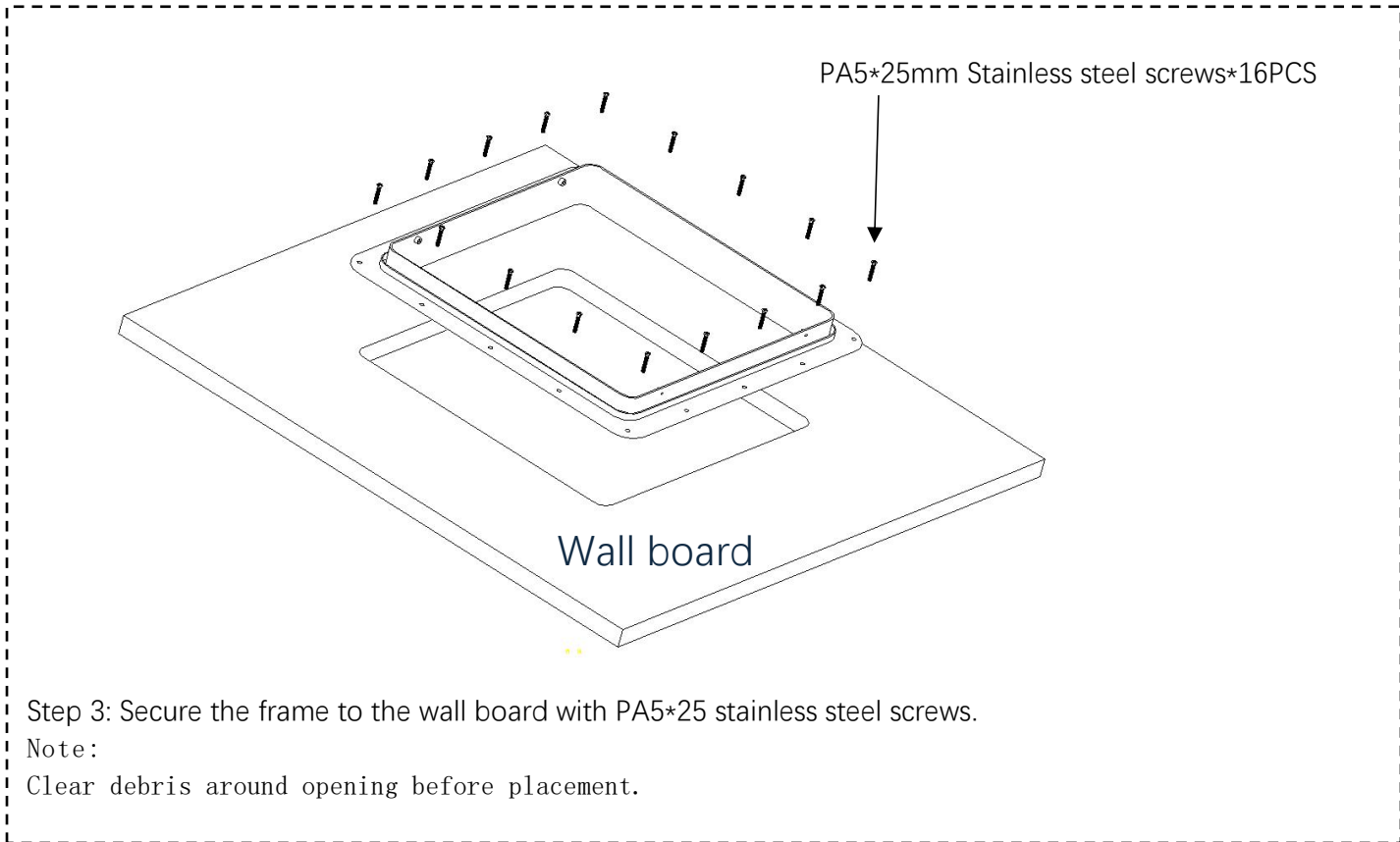
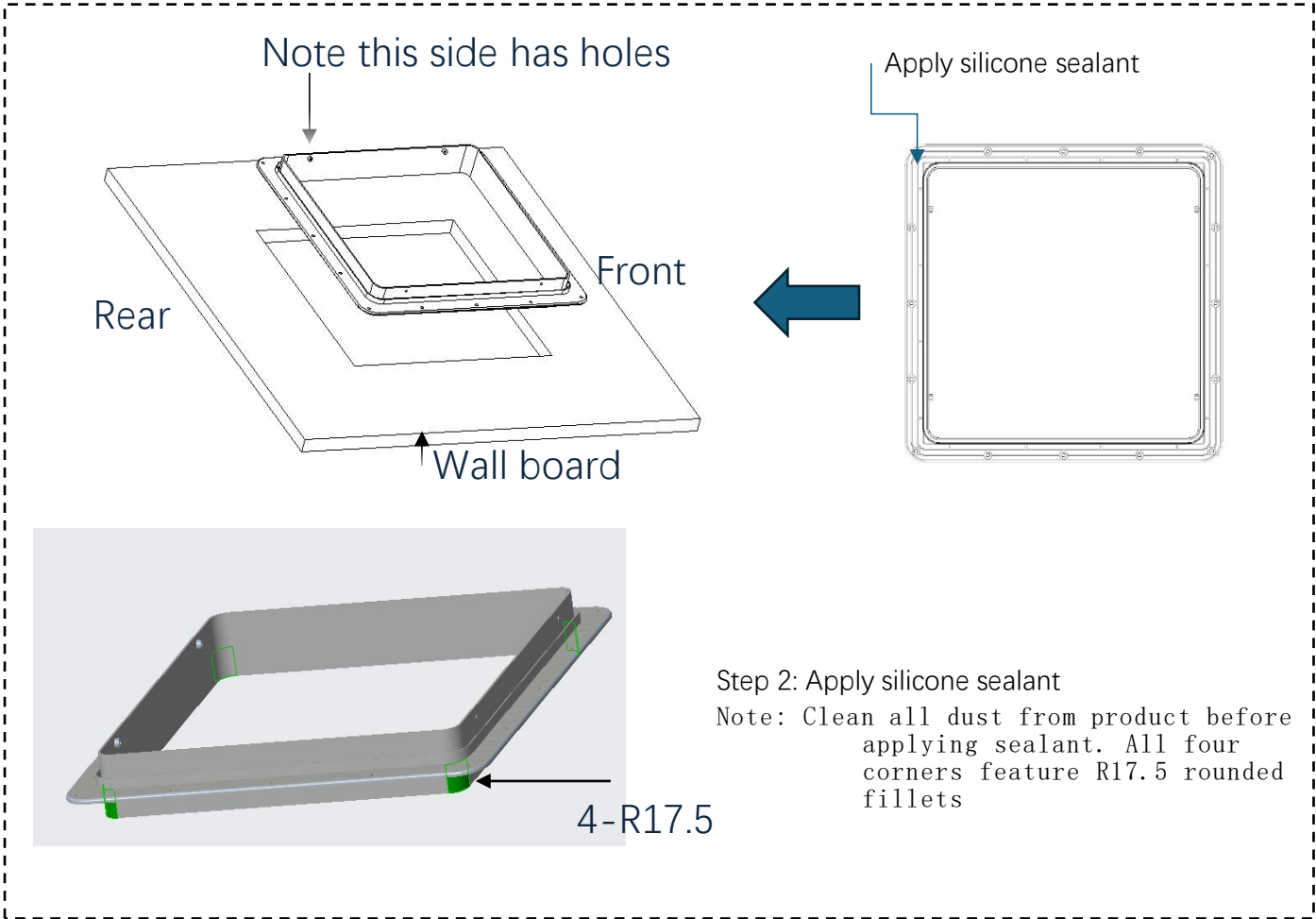

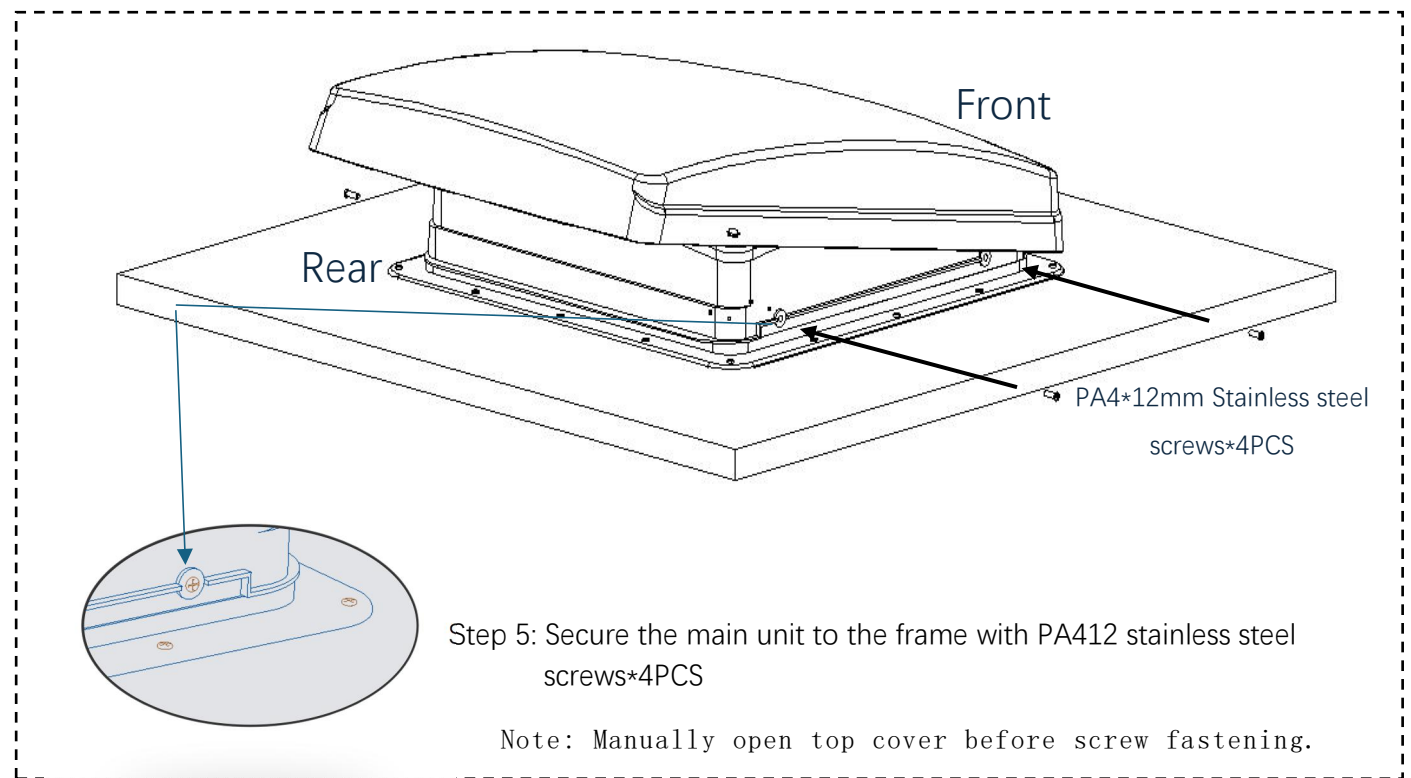
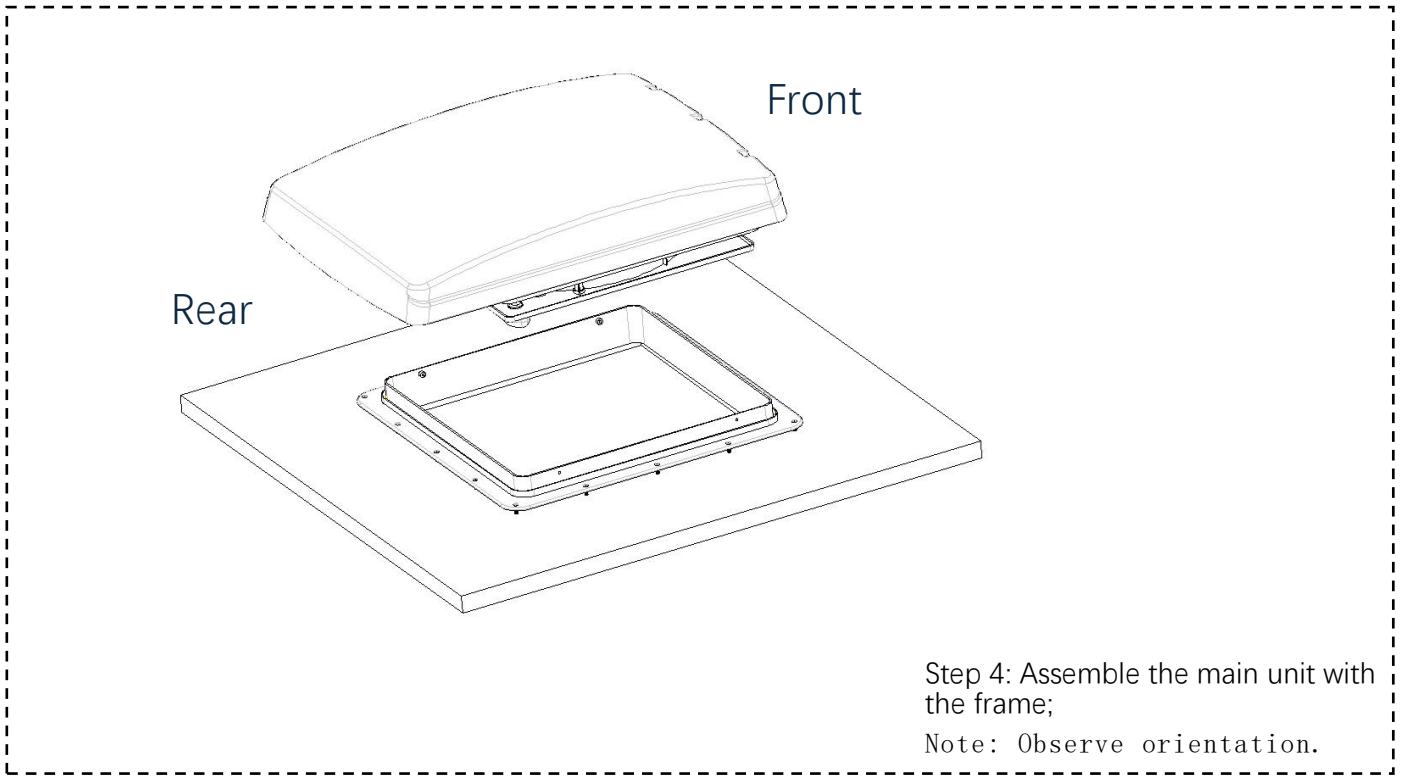

ST4*25 cross recessed countersunk
self-tapping screws*8PCS

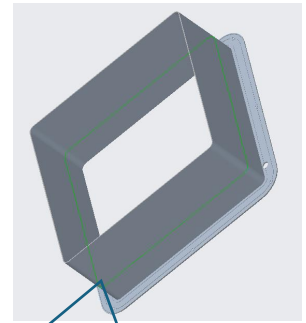
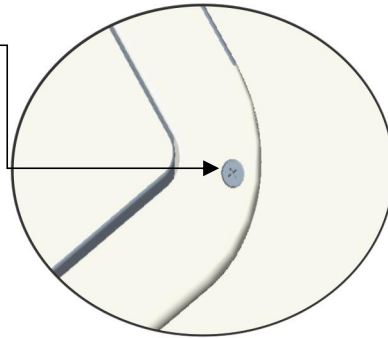
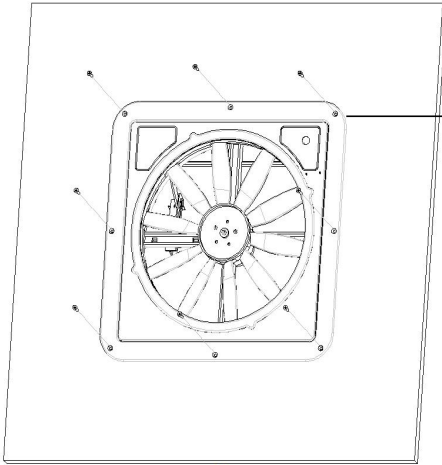

Trim decorative frame
to wall board
thickness

Step 6:

6.1: Trim the decorative frame to the wall board thickness, just covering inner frame;

6.2: Fix the decorative frame to the wall board with ST4*25mm countersunk screws*8PCS.

PA4*25 Stainless
steel screws*8PCS

Lamp covers*4PCS

Knob extension rod

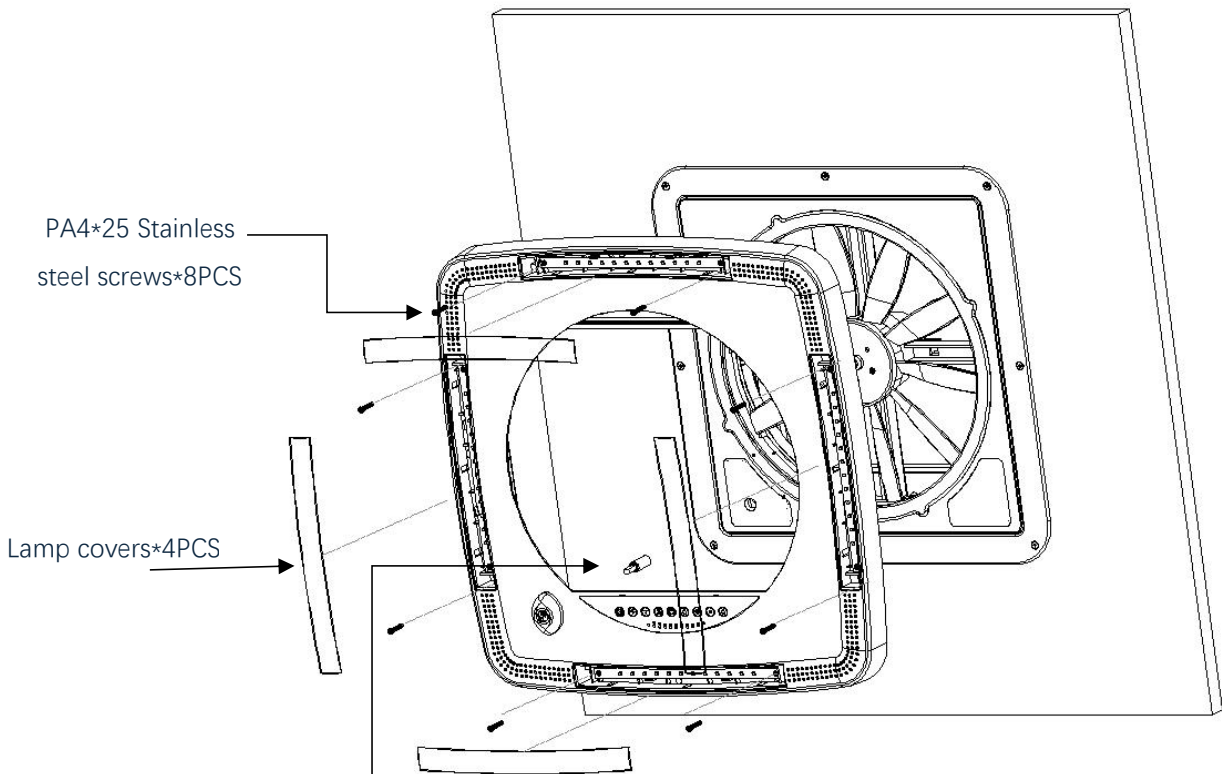

Step 7: Secure the panel to the wall board with PA425mm screws*8PCS, then install the lamp covers and connect wires as shown.

Note: Install knob and knob extension rod before panel mounting, then trim the knob extension rod to match wall thickness.

Wiring

Route cables through frame holes

Connect to control board (red to red/white to white terminals)

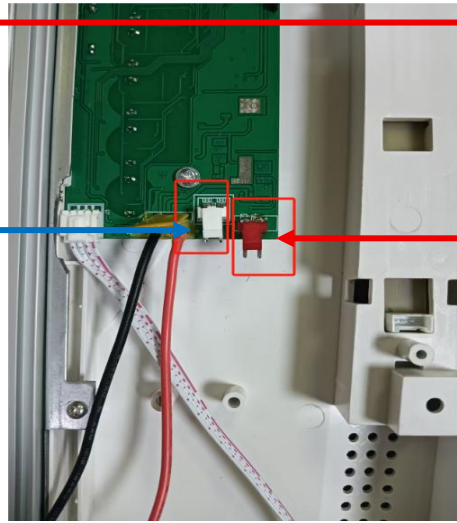
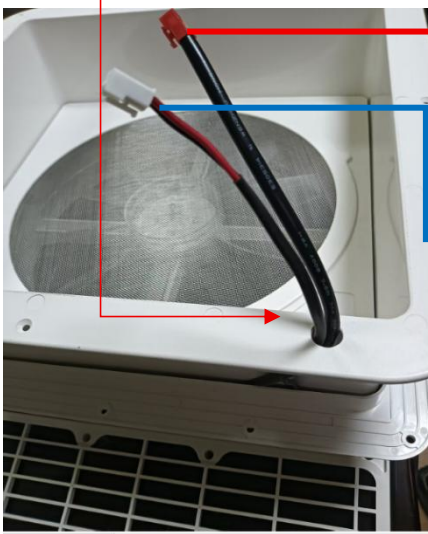

Lamp cover removal:

Gently pry from side using blade to remove the cover



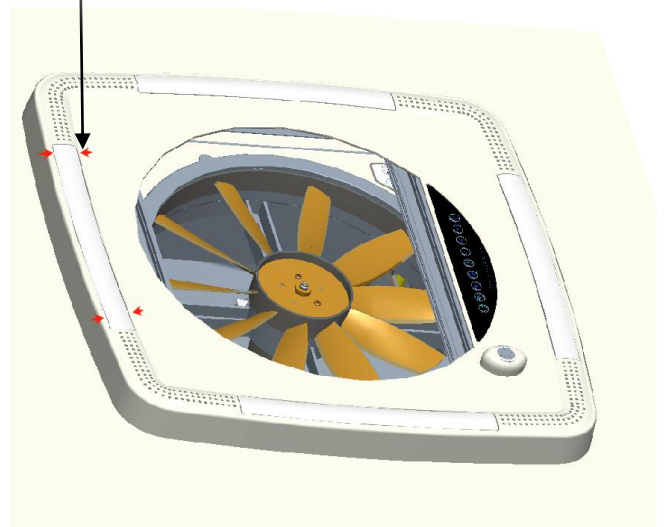



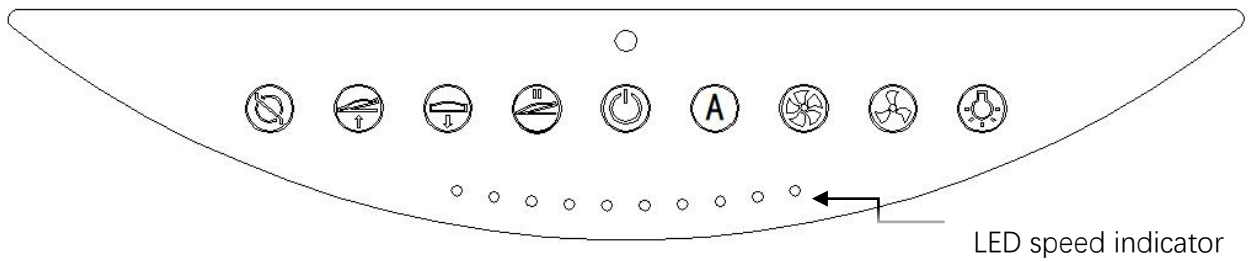

All 4 sides can be used for removal



III. Control Panel



※ Button Functions

	Power switch		Auto mode
	Cover movement pause		Increase fan speed. Note: 10 speeds total, LED indicators progress left-to-right
	Close cover		Decrease fan speed. Note: 10 speeds total, LED indicators regress right-to-left
	Open cover		3-color LED: Press once to turn on, double-press to cycle colors (1: warm white, 2: pure white, 3: blue)
	Exhaust/intake toggle (Blue LED=exhaust, Orange LED=intake)		

Remote Control

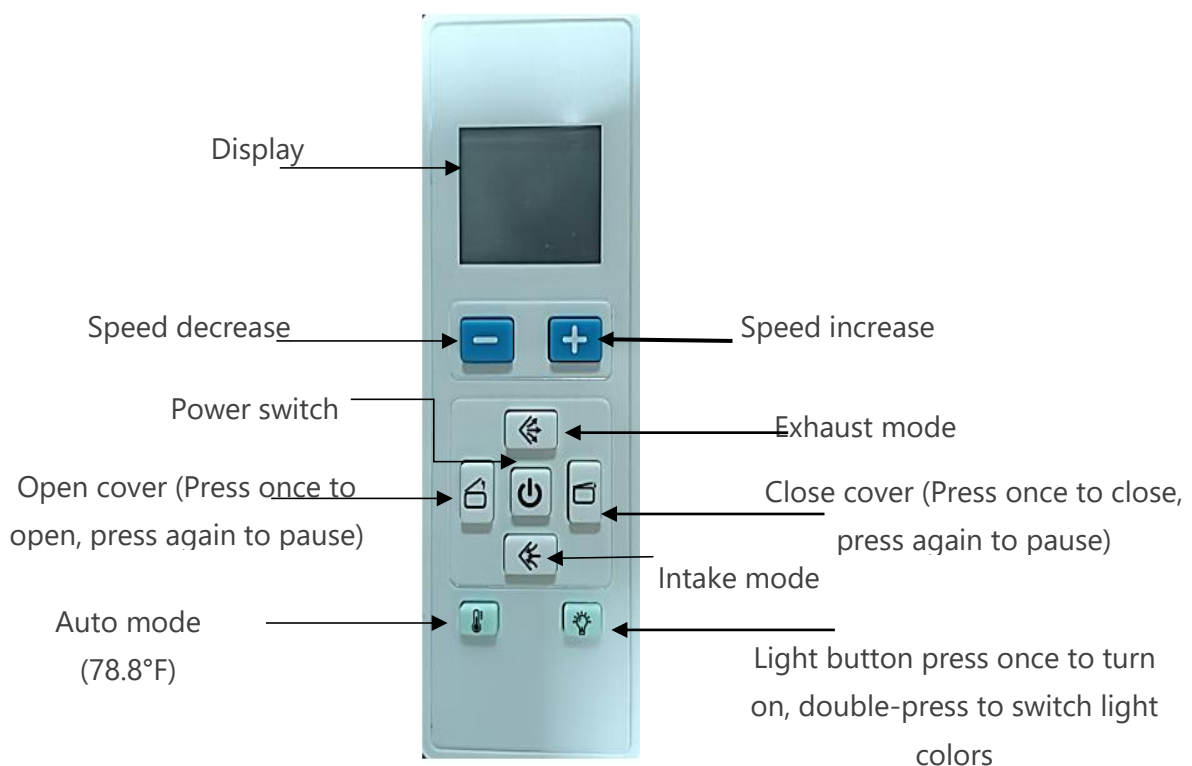

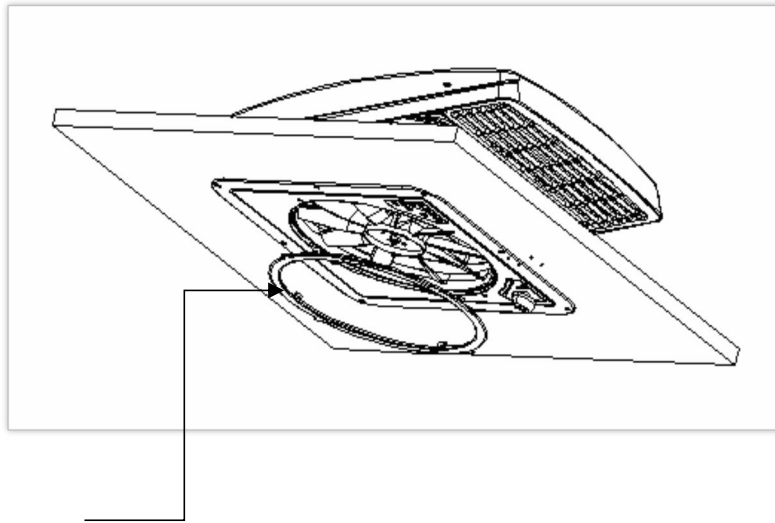

Anti-mosquito screen: Detachable for debris cleaning

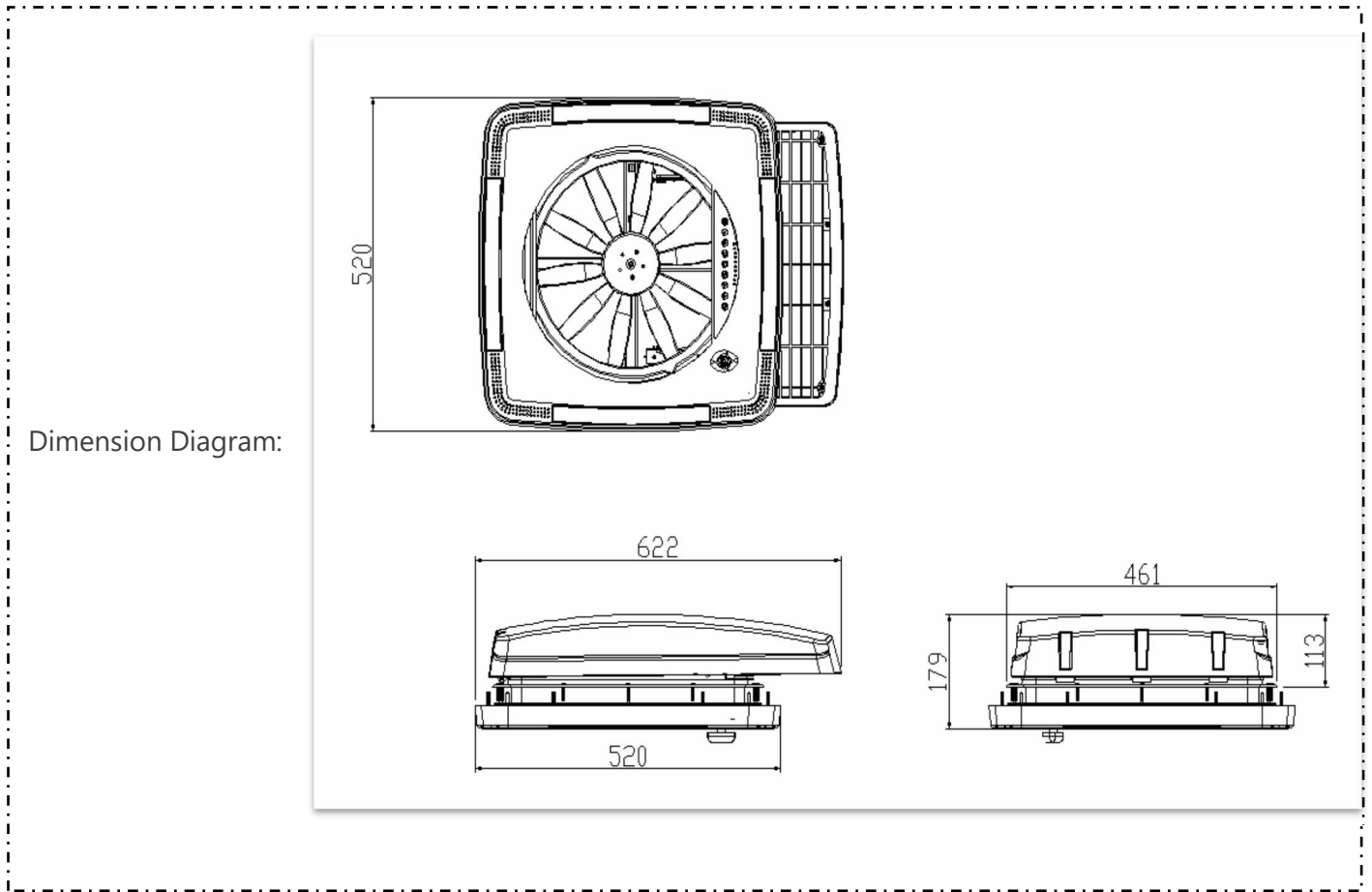

※. Operation and maintenance instructions

1. If there is any problem with the product, please contact the dealer.
2. Manual Cover Operation: Turn the knob counterclockwise to open or clockwise to close the cover.
3. Maximum open state: Fully open at 11°.
4. Check that the cover is closed when the vehicle runs, to prevent the product against damage.
5. When cleaning the inner and outer frames of the ventilator, do not use any cleaning products, chemicals or polishing equipment. Only use water and soft cloth.
6. Dust or debris on the ventilator can be removed with a dust remover. Do not use strong winds in case of damage to the product.
7. The ventilator is designed to be rainwater proof. However, horizontal water flow with high pressure may harm the product.
8. When opened, this is a rainproof ventilator for stationary vehicles.