

↗ DOMETIC

REFRIGERATION

10-SERIES

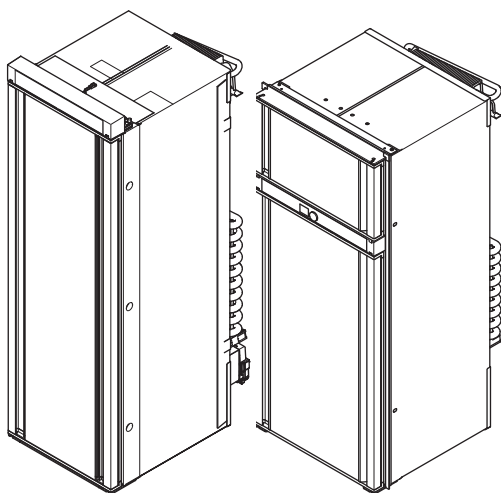

RML 10.4(T)(S)
RMD 10.5(X)(T)(S)
RMDT 10.5(X)T

EN	Absorber refrigerator Short operating manual	3
DE	Absorber-Kühlschrank Kurzbedienungsanleitung	10
FR	Réfrigérateur à absorption Guide rapide	
ES	Nevera con extractor Guía rápida	25
PT	Frigorífico de absorção Manual do utilizador resumido	33
IT	Frigorifero ad assorbimento Manuale dell'utente breve	40
NL	Absorptiekoelkast Korte gebruikershandleiding	47

DA	Absorber-køleskab Lynvejledning	54
SV	Absorptionskylskåp Kortfattad användarhandbok	61
NO	Absorbsjons-kjøleskap Hurtigveiledning	68
FI	Absorptiojääkaappi Pikaopas	75
RU	Абсорбционный холодильник Краткая инструкция по эксплуатации	82
PL	Lodówka absorpcyjna Krótka instrukcja obsługi	89
SK	Absorpcná chladnička Stručný návod	96
CS	Absorpcní lednička Stručný návod	103
HU	Abszorberes hűtőszekrény Rövid használati útmutató	110
SL	Absorpcijski hladilnik Kratek priročnik za uporabo	117
EL	Ψυγείο υγραερίου/ρεύματος Σύντομος οδηγός	124

© 2020 Dometic Group. The visual appearance of the contents of this manual is protected by copyright and design law. The underlying technical design and the products contained herein may be protected by design, patent or be patent pending. The trademarks mentioned in this manual belong to Dometic Sweden AB. All rights are reserved.

Please read this instruction manual carefully before first use, and store it in a safe place. If you pass on the product to another person, hand over this instruction manual along with it.



You find the detailed operating manual and information on the technical data online at: "dometic.com/manuals".



WARNING!

Observe also the safety instructions on the leaflet.

Table of contents

1	Safety instructions	3
2	Intended use	7
3	Using the device	8
4	Cleaning and maintenance	8
5	Warranty	9
6	Disposal	9

1 Safety instructions

The manufacturer accepts no liability for damage in the following cases:

- Damage to the product resulting from mechanical influences and incorrect connection voltage
- Alterations to the product without express permission from the manufacturer
- Use for purposes other than those described in the operating manual

1.1 General safety



WARNING! Failure to obey these warnings could result in death or serious injury.

Electrocution hazard

- Installation and removal of the device may only be carried out by qualified personnel.

- Do not operate the device if it is visibly damaged.
- This device may only be repaired by qualified personnel. Improper repairs can result in considerable danger or damage to the device.

Fire hazard

- The refrigerant in the refrigerant circuit is highly flammable. In the event of any damage to the refrigerant circuit (smell of ammonia):
 - Switch off the device.
 - Avoid naked flames and sparks.
 - Air the room well.

Explosion hazard

- Do not store any explosive substances, such as spray cans with propellants, in the device.

Health hazard

- This device can be used by children aged from 8 years and above and persons with reduced physical, sensory or mental capabilities or lack of experience and knowledge if they have been given supervision or instruction concerning use of the device in a safe way and understand the hazards involved.
- Children shall not play with the device.
- Cleaning and user maintenance shall not be made by children without supervision.
- Children aged from 3 to 8 years are allowed to load and unload cooling devices.

Children beware

- Make sure that the shelves are mounted and secured so that children cannot lock themselves in the device.
- Before disposing of your old refrigerator:
 - Dismantle the drawers.
 - Leave the shelves in the refrigerator so that children cannot climb inside.

**NOTICE! Damage hazard**

- Keep the condensation opening clean at all times.
- The device lighting may only be replaced by customer service.
- Do not use a high-pressure cleaner near the ventilation grill when cleaning the vehicle.

- Attach the winter covers of the ventilation grille (accessories) when the vehicle is cleaned from the outside or not used for a prolonged period of time.

1.2 Safe operation



CAUTION! Failure to obey these cautions could result in minor or moderate injury.

Risk of injury

- Close and lock the device door before beginning a journey.
- The cooling aggregate at the back of the device becomes very hot during operation. Protect yourself from coming into contact with hot parts when removing ventilation grills.



NOTICE! Damage hazard

- Do not use electrical devices inside the device.
- Ensure that the ventilation openings are not covered.

1.3 Safety when operating with gas



WARNING! Failure to obey these warnings could result in death or serious injury.

Explosion hazard

- **Only** operate the device at the pressure shown on the type plate. Only use pressure controllers with a fixed setting which comply with the national regulations.
- While driving only operate the device with gas if the vehicle manufacturer allows the operation of the gas system while driving (see vehicle's manual).
- Check the national requirements for operating the device with gas during driving.
- Never operate the device with gas:
 - At petrol stations
 - In parking garages
 - On ferries
 - While transporting the caravan or mobile home with a transport vehicle or tow truck
- Never use a naked flame to check the device for leaks.

- In case of gas odor:
 - Close the gas supply cock and the valve on the cylinder.
 - Open all windows and leave the room.
 - Do not press an electric switch.
 - Put out any naked flames.
 - Have the gas system checked by a specialist.

**NOTICE! Damage hazard**

- Only use propane or butane gas, **not** natural gas (see rating plate).

**NOTE**

- Ignition problems may occur at altitudes above 1000 m. Switch to a different energy source.

1.4 Safety when operating

**CAUTION! Failure to obey these cautions could result in minor or moderate injury.****Health hazard**

- Make sure that you only put items in the device which may be chilled at the selected temperature.
- Food may only be stored in its original packaging or in suitable containers.
- Opening the door for long periods can cause significant increase of the temperature in the compartments of the device.
- Clean regularly surfaces that can come in contact with food and accessible drainage systems.
- Store raw meat and fish in suitable containers in the device, so that it is not in contact with or drip onto other food.
- If the device is left empty for long periods:
 - Switch off the device.
 - Defrost the device.
 - Clean and dry the device.
 - Leave the door open to prevent mould developing within the device.
- If the refrigerator is exposed to a room temperature of below +10 °C for an extended period of time, a uniform temperature cannot be guaranteed in the freezer compartment. This can lead to an increase of the freezer compartment temperature and the goods stored in it may defrost.

Risk of injury

- The device door or the freezer door can completely detach from the device if used incorrectly. Push the doors closed until you hear a clear click at the top and bottom.
- Do not lean on the open device door.

**NOTICE! Damage hazard**

- If the door is not locked correctly on the opposite side, push on that side at the top and the bottom until it locks in place.
- Only store heavy objects such as bottles or cans in the device door, in the vegetable compartment or on the bottom shelf.

**NOTE**

- Ask your vehicle manufacturer if the battery management of your vehicle shuts down the devices to protect the battery.
- Put the device door and the freezer door into the winter position if you are not going to use the device for a longer period of time. This prevents mold from forming.
- For ambient temperatures of +15 °C to +25 °C, select the average temperature setting.

2 Intended use

The device is suitable for:

- Installation in caravans and motor caravans
- Cooling, deep-freezing and storing food

The device is **not** suitable for:

- Storage of medications
- Storage of corrosive or solvent-containing substances
- Quick-freezing of food

3 Using the device

Proceed as shown:

- Switching on the device: fig. **1**
- Switching off the device: fig. **2**
- Operating the device: fig. **3**
- Setting the cooling performance: fig. **4**
- Positioning the shelves: fig. **5** to fig. **6**
- Positioning the shelf at an angle for wine bottles: fig. **7** to fig. **8**
- Removing the VG fresh base: fig. **9**
- Inserting the VG fresh base: fig. **10**
- Defrosting the device: fig. **11**
- Using the winter position: fig. **12**
- Releasing the refrigerator door: fig. **13**
- Changing the batteries (optional): fig. **14**
- Removing the freezer compartment: fig. **15**
- Positioning the oven shelves: fig. **17** to fig. **18**
- Switching on the oven or grill: fig. **19**
- Setting the oven temperature: fig. **20**
- Switching off the oven or grill: fig. **21**

4 Cleaning and maintenance

Proceed as shown:

- Cleaning the gas burner: fig. **16**
 - after not being used for a longer period
 - at least once a year

5 Warranty

The statutory warranty period applies. If the product is defective, please contact the manufacturer's branch in your country (see dometic.com/dealer) or your retailer.

For repair and warranty processing, please include the following documents when you send in the device:

- A copy of the receipt with purchasing date
- A reason for the claim or description of the fault

6 Disposal



NOTE

Only have the device removed and disposed of by a specialist. This device contains flammable insulating blowing gas and ammonia R717 as refrigerant. Please check the national requirements for disposal.

If you wish to finally dispose of the product, ask your local recycling centre or specialist dealer for details about how to do this in accordance with the applicable disposal regulations.

Mobile living made easy.



dometic.com

**YOUR LOCAL
DEALER**

dometic.com/dealer

**YOUR LOCAL
SUPPORT**

dometic.com/contact

**YOUR LOCAL
SALES OFFICE**

dometic.com/sales-offices

A complete list of Dometic companies, which comprise the Dometic Group, can be found in the public filings of:
DOMETIC GROUP AB Hemvärnsgatan 15 SE-17154 Solna Sweden