

↗ DOMETIC REFRIGERATION CRX



CRX50, CRX65, CRX80, CRX110, CRX140

EN

Compressor refrigerator
Installation and Operating Manual

© 2020 Dometic Group. The visual appearance of the contents of this manual is protected by copyright and design law. The underlying technical design and the products contained herein may be protected by design, patent or be patent pending. The trademarks mentioned in this manual belong to Dometic Sweden AB. All rights are reserved.

Please read this instruction manual carefully before installation and first use, and store it in a safe place. If you pass on the product to another person, hand over this instruction manual along with it.

Table of contents

1	Explanation of symbols	4
2	Safety instructions	4
3	Scope of delivery	8
4	Accessories	8
5	Intended use	9
6	Technical description	9
7	Installing and connecting the refrigerator	16
8	Using the refrigerator	29
9	Cleaning and maintenance	34
10	Limited warranty	34
11	Disposal	35
12	Troubleshooting	35
13	Technical data	39

1 Explanation of symbols

**DANGER!**

Safety instruction: Indicates a hazardous situation that, if not avoided, will result in death or serious injury.

**WARNING!**

Safety instruction: Indicates a hazardous situation that, if not avoided, could result in death or serious injury.

**CAUTION!**

Safety instruction: Indicates a hazardous situation that, if not avoided, could result in minor or moderate injury.

**NOTICE!**

Indicates a situation that, if not avoided, can result in property damage.

**NOTE**

Supplementary information for operating the product.

2 Safety instructions

The manufacturer accepts no liability for damage in the following cases:

- Faulty assembly or connection
- Damage to the product resulting from mechanical influences and incorrect connection voltage
- Alterations to the product without express permission from the manufacturer
- Use for purposes other than those described in the operating manual

2.1 General safety



DANGER! Failure to obey these warnings will result in death or serious injury.

Electrocution hazard

- On boats: If the device is powered by the mains, ensure that the power supply has a residual current circuit breaker.



WARNING! Failure to obey these warnings could result in death or serious injury.

Electrocution hazard

- Installations in washrooms and areas exposed to water, must be performed by a qualified technician.
- Do not operate the device if it is visibly damaged.
- If this device's power cable is damaged, it must be replaced by the manufacturer, customer service or a similarly qualified person in order to prevent safety hazards.
- This device may only be repaired by qualified personnel. Inadequate repairs may cause serious hazards.

Health hazard

- This device can be used by children aged from 8 years and above and persons with reduced physical, sensory or mental capabilities or lack of experience and knowledge if they have been given supervision or instruction concerning use of the device in a safe way and understand the hazards involved.
- Children shall not play with the device.
- Cleaning and user maintenance shall not be made by children without supervision.
- Children aged from 3 to 8 years are allowed to load and unload refrigerating devices.

Explosion hazard

- Do not store any explosive substances, such as spray cans with propellants, in the device.



CAUTION! Failure to obey these cautions could result in minor or moderate injury.

Risk of crushing

- Do not put your fingers into the hinge.

Health hazard

- Foodstuff may only be stored in its original packaging or in suitable containers.



NOTICE! Damage hazard

- Check that the voltage specification on the type plate is the same as that of the power supply.
- Never pull the plug out of the socket by the connection cable.

- If the device is connected to the DC socket: Disconnect the device and other electric consumers from the battery before connecting the quick charging device.
- If the device is connected to the DC socket: Disconnect the device or switch it off when you turn off the engine. Otherwise you may discharge the battery.
- The device is not suitable for storing substances which are caustic or contain solvents.
- Keep the drainage outlet clean at all times.
- Do not open the refrigerant circuit under any circumstances.
- Never transport the device in a horizontal position, so that no oil can leak out of the compressor.
- Make sure that the refrigerant circuit is not damaged during transportation. The refrigerant in the refrigerant circuit is highly flammable. In the event of any damage to the refrigerant circuit:
 - Avoid naked flames and sparks.
 - Air the room well.
- Set up the device in a dry location where it is protected against splashing water.

2.2 Operating the device safely



DANGER! Failure to obey these warnings will result in death or serious injury.

Electrocution hazard

- Do not touch exposed cables with your bare hands. This applies especially when operating the device from the AC mains.



CAUTION! Failure to obey these cautions could result in minor or moderate injury.

Electrocution hazard

- Before starting the device, ensure that the power supply line and the plug are dry.

Health hazard

- Opening the door for long periods can cause significant increase of the temperature in the compartments of the device.
- Clean regularly surfaces that can come in contact with food and accessible drainage systems.

- Store raw meat and fish in suitable containers in the device, so that it is not in contact with or can drip onto other food.
- If the device is left empty for long periods:
 - Switch off the device.
 - Defrost the device.
 - Clean and dry the device.
 - Leave the door open to prevent mould developing within the device.

**NOTICE! Damage hazard**

- Do not use electrical devices inside the cooling device unless they are recommended by the manufacturer for that purpose.
- Do not place it near naked flames or other heat sources (heaters, direct sunlight, gas ovens etc.)
- **Danger of overheating!**
Always ensure sufficient ventilation so that the heat generated during operation can dissipate. Make sure that the device is sufficiently far away from walls and other objects so that the air can circulate.
- Ensure that the ventilation vents are not covered.
- Do not fill the inner container with ice or fluid.
- Never immerse the device in water.
- Protect the device and the cable against heat and moisture.
- Make sure that foodstuffs do not touch the walls of the cooling area.

3 Scope of delivery

Quantity	Description
1	Refrigerator with shelves
1	Water drain outlet
1	Installation and operating manual

4 Accessories

Available as accessories (not included in the scope of delivery):

Description	Explanation	Ref. no.
Rectifier	Suitable for CRX50DC, CRX65DC, CRX80DC, CRX110DC. Transforms an input voltage of 100 – 240 V \sim to 24 V \equiv , so that the refrigerator can be connected to an AC power supply.	9600000445
Mounting Frames	Flush-mount and standard mounting frames are available for all CRX models.	Various

If you have any questions, please contact the dealer or your service partner directly.

5 Intended use

The refrigerator is designed for installation in caravans and motorhomes and on boats. It is recommended the unit is installed into a fixed position. Once it is installed, only the front of the appliance may be accessible

The refrigerator is only suitable for cooling, freezing and storing foodstuffs. The refrigerator is not intended for the proper storage of medicine.

For DC only version: The refrigerator must only be supplied at safety extra low voltage corresponding to the marking on the refrigerator.



CAUTION! HEALTH HAZARD

Please check if the cooling capacity of the refrigerator is suitable for storing the food you wish to cool.

6 Technical description

The CoolMatic CRX series cooling appliances can cool products and keep them cool. Products can be deep-frozen in the freezer compartment. If the refrigerator is operated without a freezer compartment, frozen products can be stored in the short term using the fast-cooling function.

All materials used in the refrigerator are compatible for use with foodstuffs. The refrigerant circuit is maintenance-free.

The cooling device can withstand a short-term inclination of 30°, for example on boats.

The temperature is set using the control panel on the inside left of the refrigerator.

CRX50, CRX65, CRX80

Four temperature ranges from +3 °C (37 °F) to +12 °C (54 °F), and a fast-cooling function, are available for selection.

CRX110, CRX140

Four temperature ranges from +3 °C (37 °F) to +12 °C (54 °F) are available for selection.

CRX110ACDC, CRX140ACDC

Four temperature ranges from +3 °C (37 °F) to +12 °C (54 °F), and a winter mode, are available for selection.

6.1 Control elements inside the refrigerator

The various types of refrigerators are shown in the following illustrations:

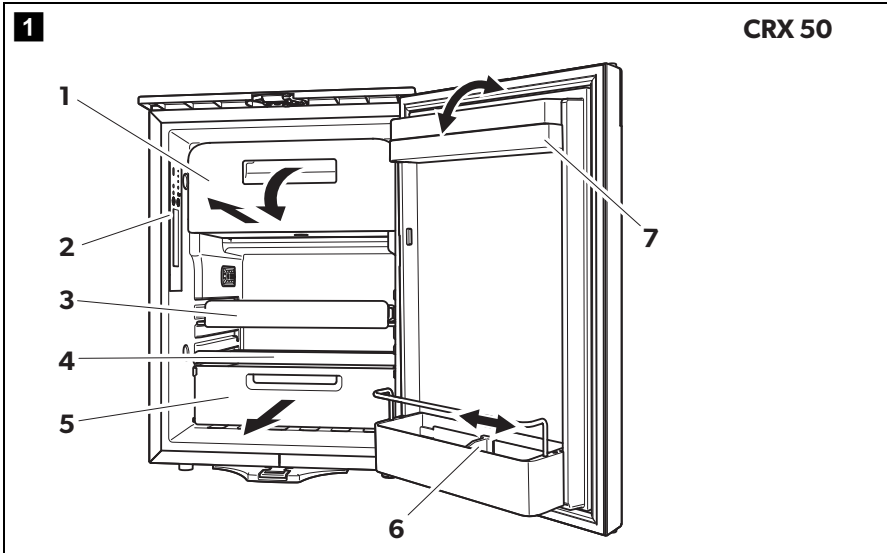

- CRX50: fig. **1**

No.	Explanation
1	Freezer compartment (detachable: CRX50, CRX65, CRX80 only)
2	Control panel
3	Wire shelf (folding, so that bottles can be put in the refrigerator)
4	Shelf
5	Fruit compartment
6	Bottle restraint (to hold bottles in the door)
7	Compartment with lid (hinged)

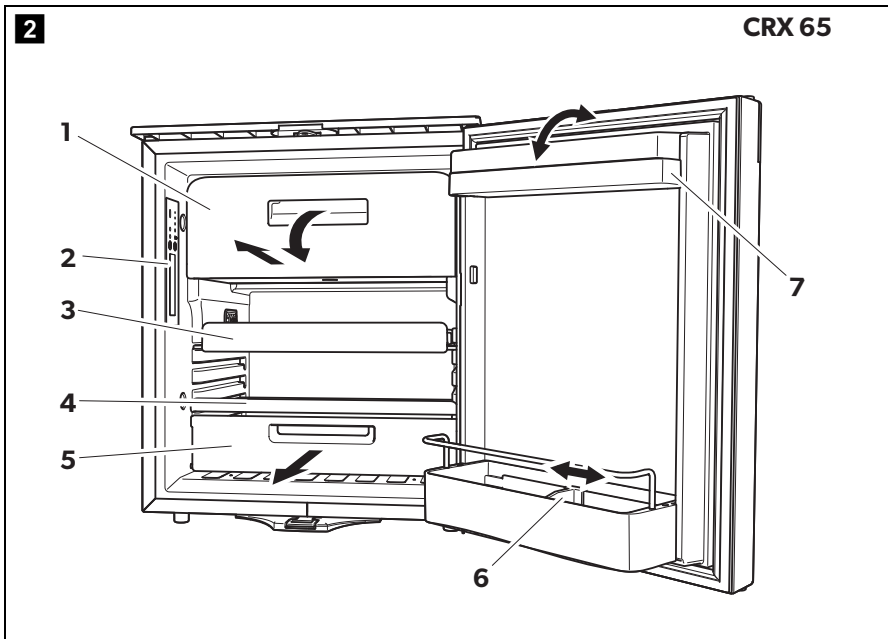

- CRX65: fig. **2**

No.	Explanation
1	Freezer compartment (detachable: CRX50, CRX65, CRX80 only)
2	Control panel
3	Wire shelf (folding, so that bottles can be put in the refrigerator)
4	Shelf
5	Fruit compartment
6	Bottle restraint (to hold bottles in the door)
7	Compartment with lid (hinged)

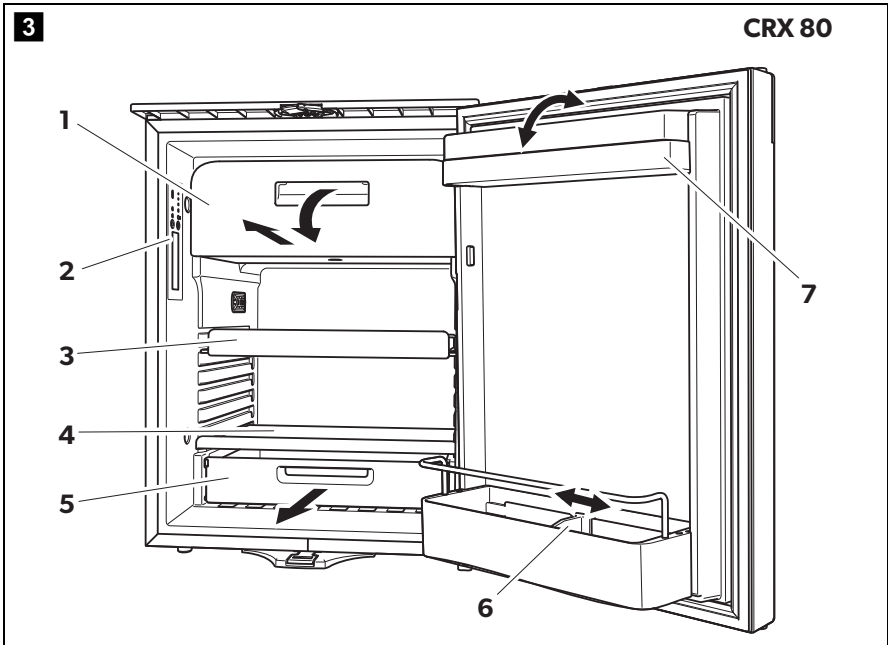

• CRX 80: fig. **3**

No.	Explanation
1	Freezer compartment (detachable: CRX50, CRX65, CRX80 only)
2	Control panel
3	Wire shelf (folding, so that bottles can be put in the refrigerator)
4	Shelf
5	Fruit compartment
6	Bottle restraint (to hold bottles in the door)
7	Compartment with lid (hinged)

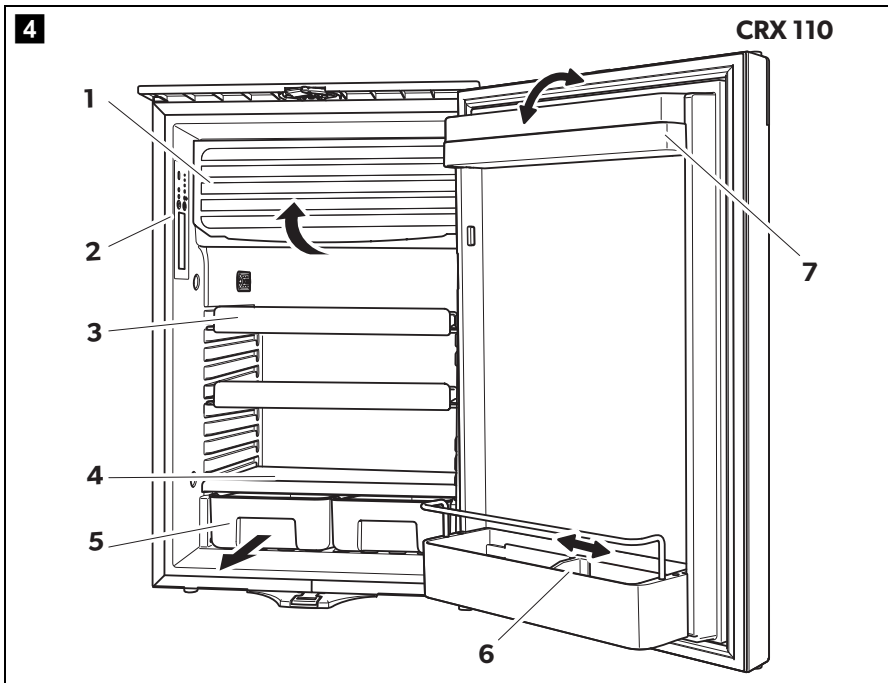

- CRX110: fig. **4**

No.	Explanation
1	Freezer compartment (detachable: CRX50, CRX65, CRX80 only)
2	Control panel
3	Wire shelf (folding, so that bottles can be put in the refrigerator)
4	Shelf
5	Fruit compartment
6	Bottle restraint (to hold bottles in the door)
7	Compartment with lid (hinged)

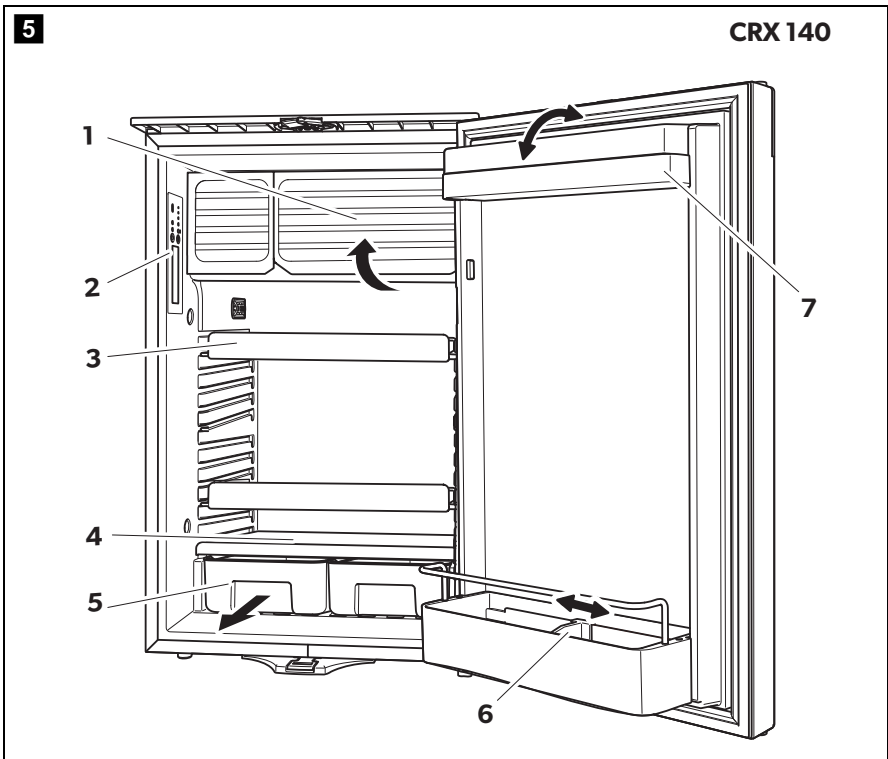

• CRX140: fig. **5**

No.	Explanation
1	Freezer compartment (detachable: CRX50, CRX65, CRX80 only)
2	Control panel
3	Wire shelf (folding, so that bottles can be put in the refrigerator)
4	Shelf
5	Fruit compartment
6	Bottle restraint (to hold bottles in the door)
7	Compartment with lid (hinged)

6.2 Control elements

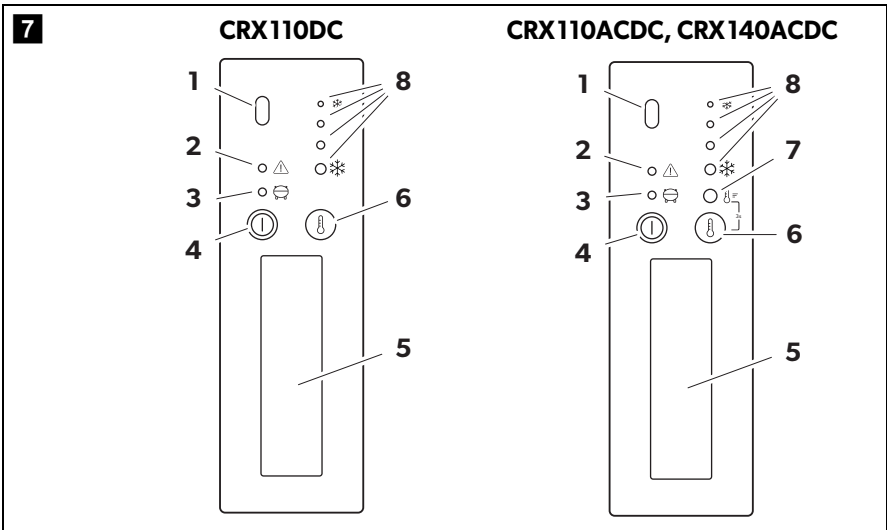
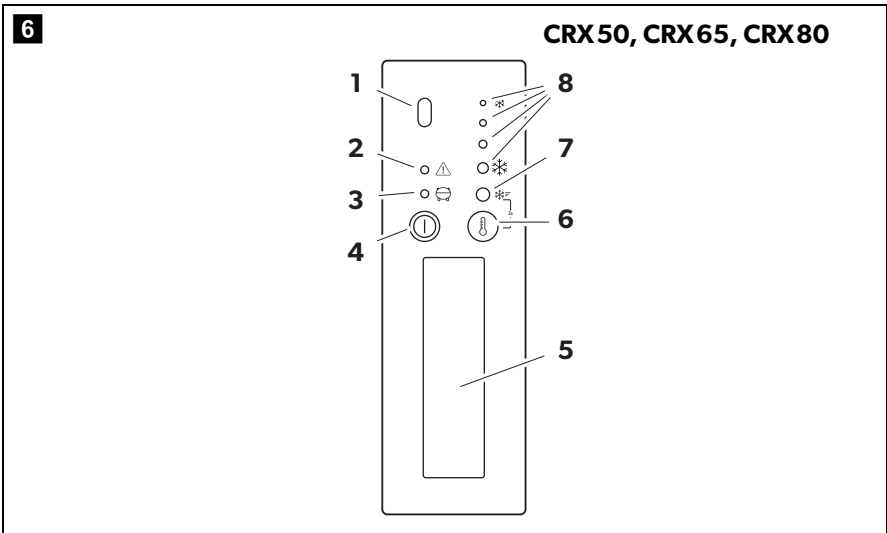

No. in fig. 6, page 15, fig. 7, page 15	Explanation
1	IR sensor for switching the interior light
2	LED Service display
3	LED Blue: Compressor is running LED Orange: Compressor is off
4	On/off button
5	Inner lighting
6	Temperature selection button
7	LED: Fast cooling function on (CRX50, CRX65, CRX80) LED: Winter mode on (CRX110ACDC, CRX140ACDC)
8	LEDs: Temperature levels

7 Installing and connecting the refrigerator

7.1 Safety instructions for installation on boats

Please note the following instructions for installation on boats:



DANGER! DANGER OF ELECTROCUTION

If the device is powered by the mains, ensure that the voltage supply has a residual current circuit breaker.

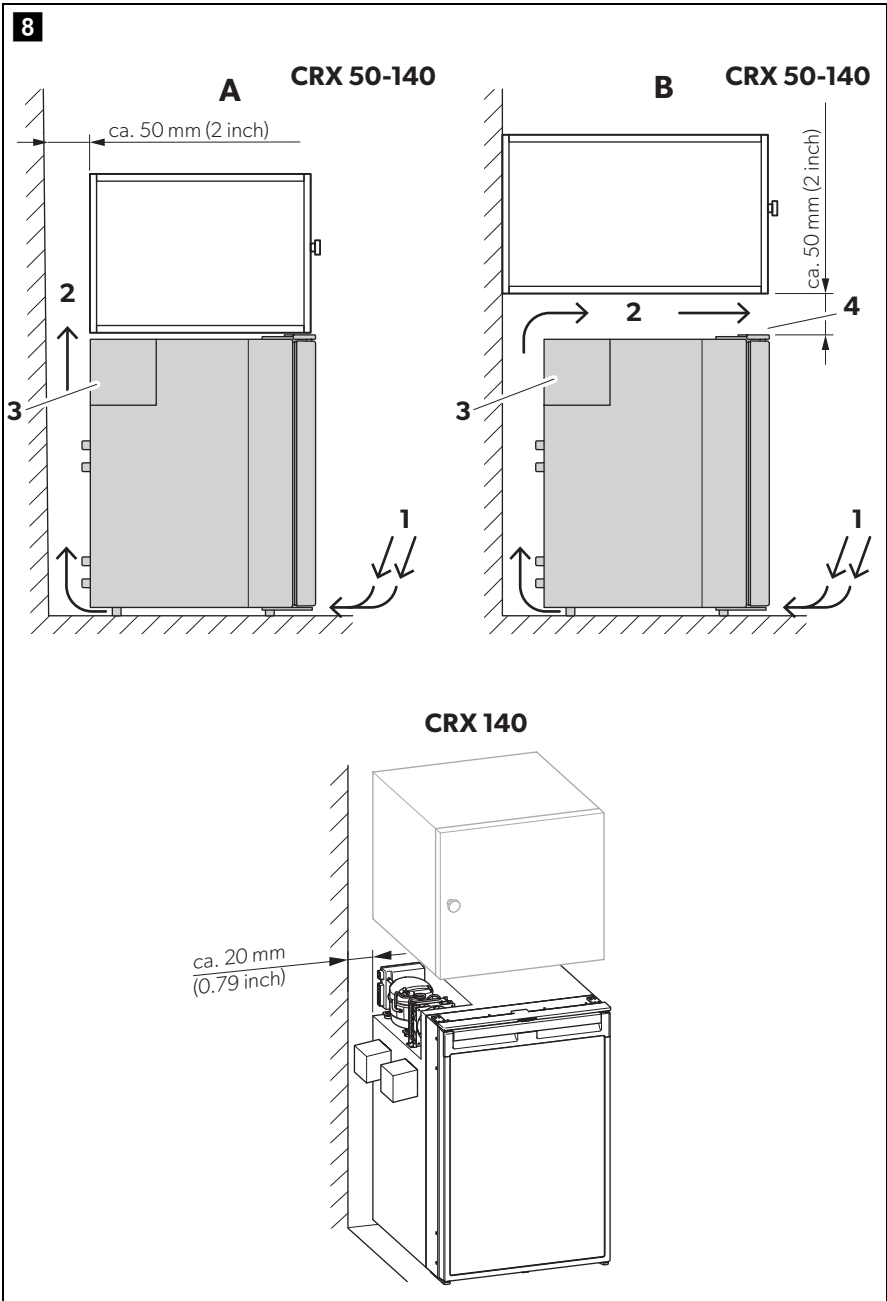



NOTICE! DANGER OF DAMAGE

- The cooling device can withstand a short term inclination of 30°, for example on boats. When setting up the refrigerator, note that it must be fastened to take account of this. If you have any questions regarding installation, consult your specialist dealer.
- Install the refrigerator so that the warm air produced can easily flow away (either upwards or to the sides, fig. **8**).
- The appliance is designed for ambient temperatures between +16 °C (61 °F) and +43 °C (109 °F).
- CRX110ACDC, CRX140ACDC: In winter mode the appliance can be operated at ambient temperatures between +10 °C (50 °F) and +16 °C (61 °F).

7.2 Notes on installing the refrigerator



WARNING! Fire hazard!

- When positioning the device, ensure the supply cord is not trapped or damaged.
- Do not locate multiple portable socket-outlets or portable power supplies at the rear of the device.

Observe the following when installing the refrigerator:

- Install the refrigerator so that the warm air produced can easily flow away (either upwards or to the sides, fig. **8**).

Key for fig. **8**

No.	Explanation
1	Cold intake air
2	Hot waste air
3	Condenser
4	Spacing above the refrigerator if there is not sufficient air to circulate above or at the side.

Observe the following installation dimensions:

Model	Dimensions W x H x D (mm)	Dimensions W x H x D (inch)
CRX50	390 x 544 x 550	15.35 x 21.42 x 21.65
CRX65	458 x 535 x 595	18.03 x 21.06 x 23.43
CRX80	485 x 650 x 578	19.09 x 25.59 x 22.76
CRX110	530 x 755 x 608	20.87 x 29.72 x 23.94
CRX140	550 x 825 x 670	21.65 x 32.48 x 26.38

- Keep objects clear of openings in the housing or installation structure (such as ventilation slots, etc.).
- Condensate is produced when the refrigerator is operating normally. You can either wipe up the condensate on the floor of the refrigerator at regular intervals, or drain it through a water drain outlet in the floor of the refrigerator (see chapter "Mounting the water drain outlet (optional)" on page 20).

7.3 Mounting the water drain outlet (optional)

**NOTE**

The fitment of the drain outlet is recommended in high humidity climates which will generate more condensate than low humidity applications.

- Connect a hose with an inside diameter of 10 mm (0.4 inch) (not included) to the water drain outlet.
- Lay the refrigerator on its side in order to access the bottom side.

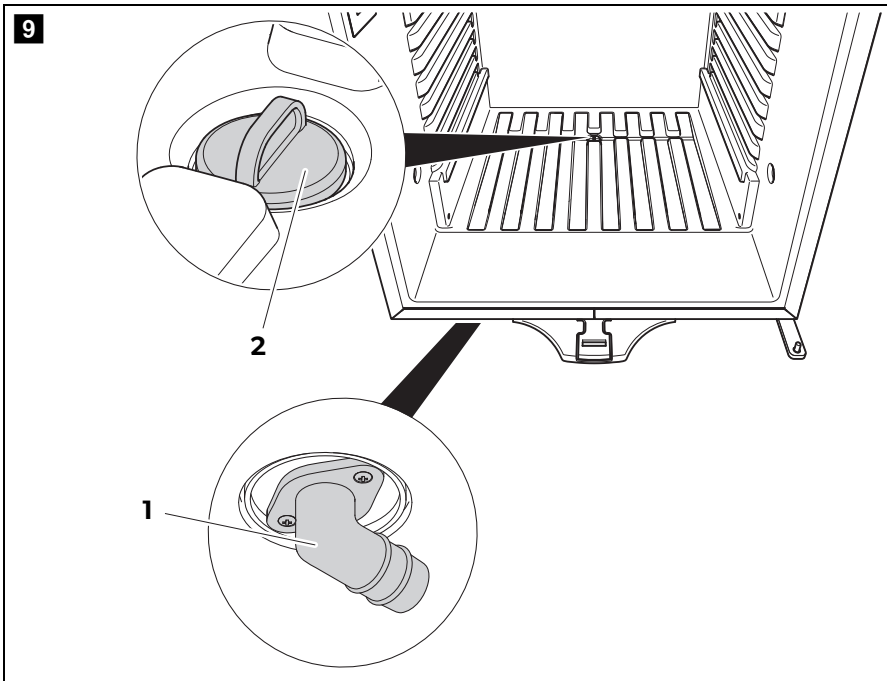

- Mount the water drain outlet (fig. 9 1) aligned to the front or to the back according to the desired direction.
- Remove the water drain plug (fig. 9 2) inside the refrigerator.

7.4 Installing the refrigerator



WARNING! INJURY HAZARD

The device must be installed in accordance with the instructions to avoid a hazard due to instability of the device.

Proceed as follows to install the refrigerator:

- If you wish to drain the condensate through a hose:
Mount the water drain port (see chapter "Mounting the water drain outlet (optional)" on page 20)
- Undo the transport lock (chapter "Releasing the lock" on page 32).
- Open the refrigerator door.

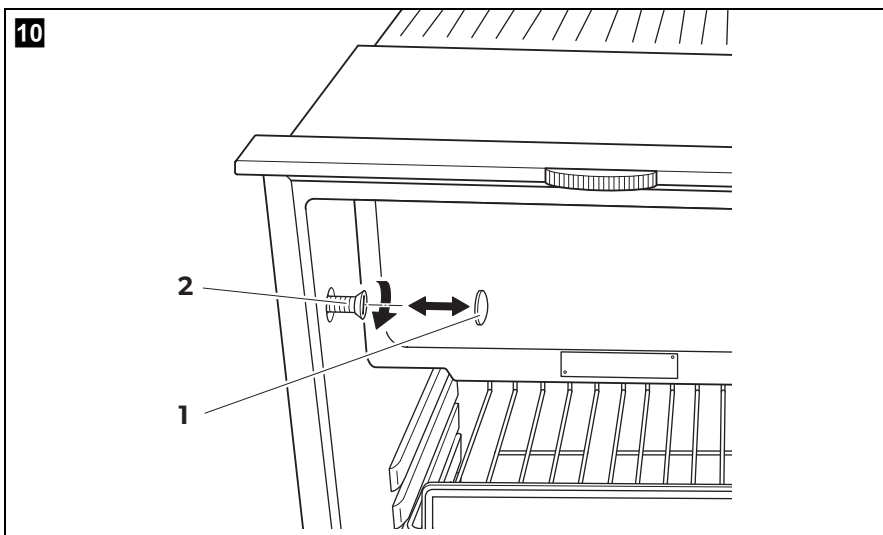

- Remove the blanking plugs (fig. 10 1).
- Push the refrigerator into the recess.
- Fix the refrigerator in place using suitable screws (fig. 10 2).
- Press the blanking plugs (fig. 10 2) into the openings.

7.5 Changing the door hinge

You can also change the hinge of the door, so that it opens to the left rather than the right.

- Proceed as shown (fig. **11** to fig. **13**).

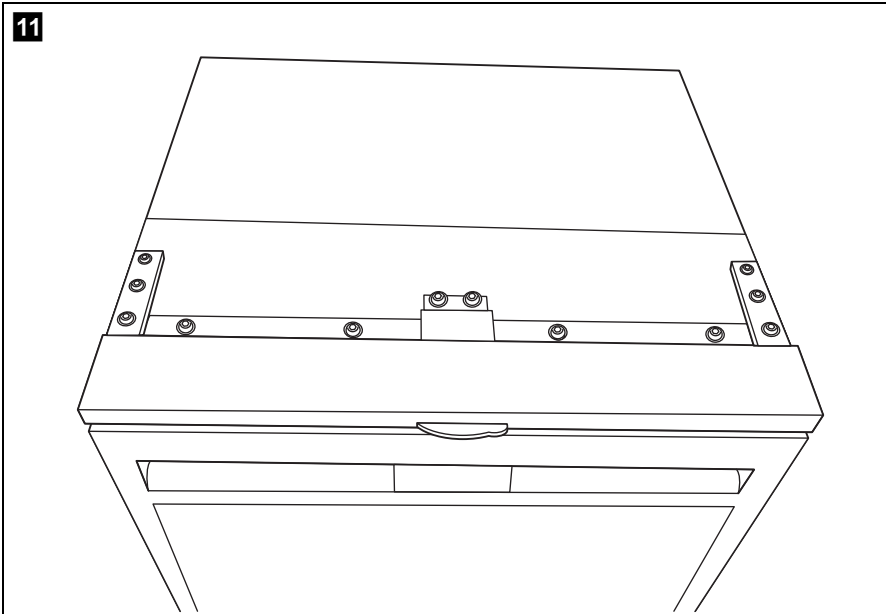

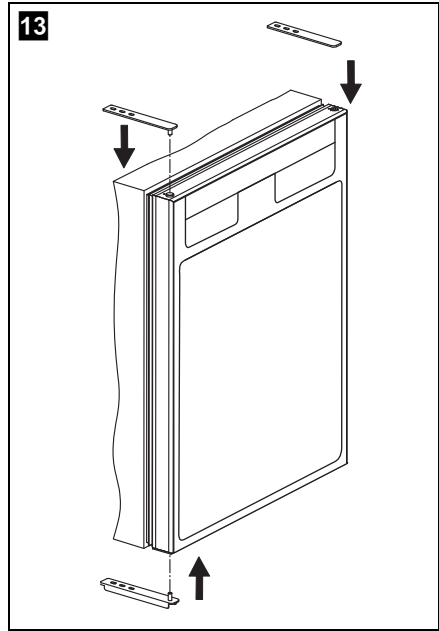
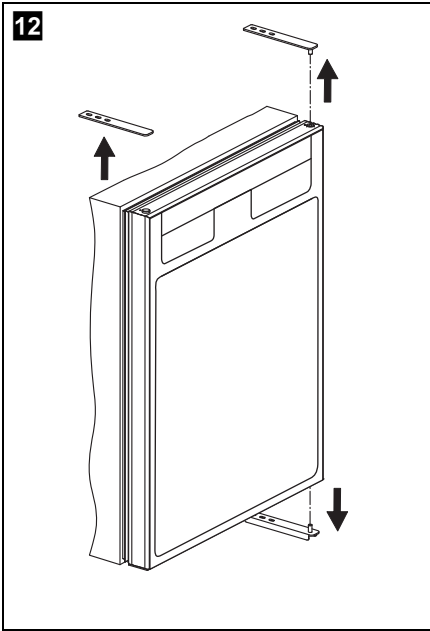

7.6 Connecting the refrigerator to DC voltage



NOTICE! DANGER OF DAMAGE

- To avoid voltage drops and loss of performance, keep the connection cable as short as possible and not be interrupted. Therefore avoid additional switches, plugs or power strips.
- Disconnect the cooling device and other electric consumers from the battery before you connect the battery to a quick charging device. Overvoltage can damage the electronics of the device.

The refrigerator can be operated with a 12 V or a 24 V DC voltage supply.

For safety reasons, the refrigerator is equipped with an electronic system to prevent the polarity being reversed. This protects the refrigerator against reversed polarity when connecting to a battery and against short circuiting.

To protect the battery, the refrigerator switches off automatically if the voltage is insufficient (see table below).

	12 V	24 V
Cut-off voltage	10.4 V	22.8 V
Cut-in voltage	11.7 V	24.2 V

- Determine the required cross section of the cable in relation to the cable length according to:

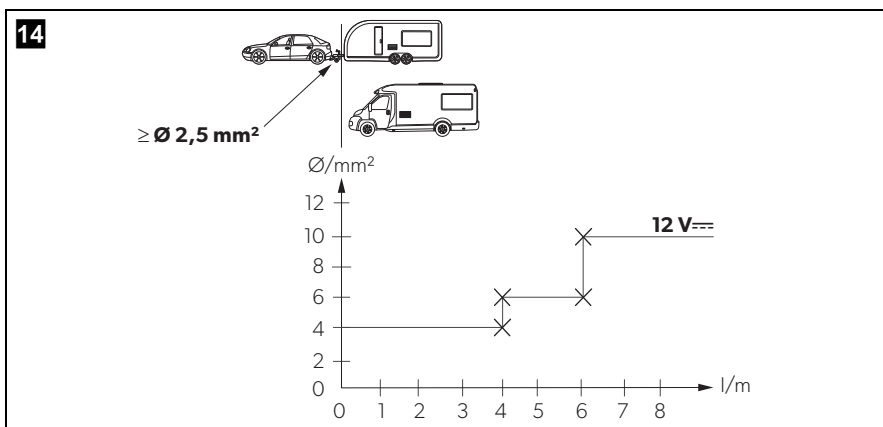

- 12 V: fig. **14**

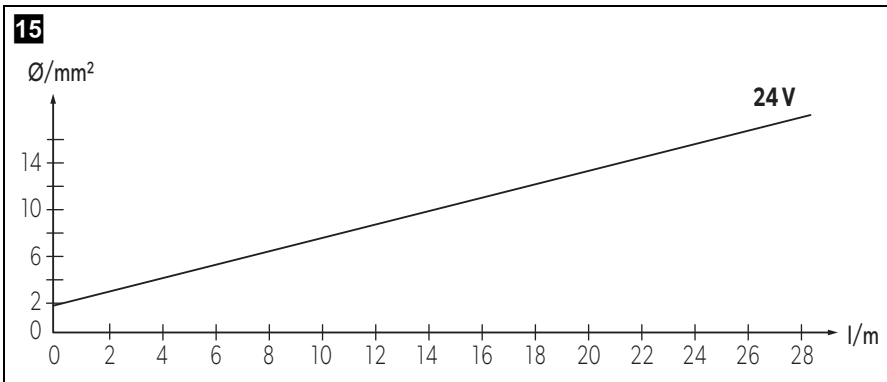

- 24 V: fig. **15**

Key to fig. **15**:

Coordinate axis	Meaning	Unit
l	Cable length	m
Ø	Cable cross section	mm^2



NOTICE! DANGER OF DAMAGE

Make sure the polarity is correct.

- Before starting up the device for the first time, check whether the operating voltage and the battery voltage match (see type plate).

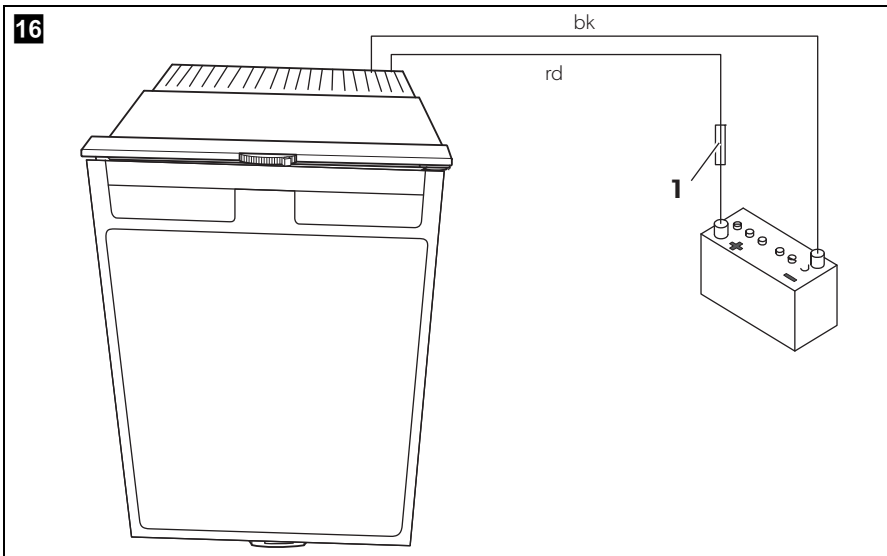

- Connect your refrigerator to a plug socket which is fuse-protected at 15 A (at 12 V) or 7.5 A (at 24 V) (fig. **16** 1.).
- Connect the red cable (fig. **16** rd) to the positive terminal of the battery.
- Connect the black cable (fig. **16** bk) to the negative terminal of the battery.

7.7 Connecting the refrigerator to AC voltage



DANGER! DANGER OF ELECTROCUTION

- Never handle plugs and switches with wet hands or if you are standing on a wet surface.
- If you are operating your refrigerator on board a boat with an AC mains connection using a shore connection, you must install a residual current circuit breaker between the AC mains supply and the refrigerator.
Seek advice from a trained technician.



NOTE

The mains socket must be easily accessible so that you can unplug the power cord if required, thereby disconnecting the refrigerator from the power.

CRX50ACDC, CRX65ACDC, CRX80ACDC, CRX110ACDC, CRX140ACDC

Proceed as follows when you connect the refrigerator to the AC supply:

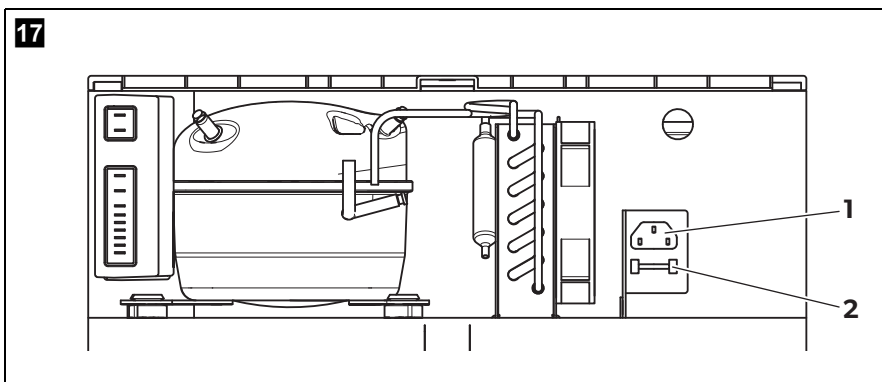

- Plug the connector into the AC socket (fig. **17** 1).

CRX50DC, CRX65DC, CRX80DC, CRX110DC

You can connect the refrigerator to 100 – 240 V~ AC power if you use the MPS 35 rectifier (**accessory**).

The MPS 35 rectifier features a priority circuit which conserves the battery connected. When a 100 – 240 V~ mains connection is used, the rectifier automatically switches from battery to mains operation.

When disconnected from the 100 – 240 V~ mains supply, the rectifier automatically switches back to battery operation. Mains operation via the rectifier always takes priority over battery operation.

In mains operation the output voltage of the rectifier will always be 24 V. When the rectifier is in 12 V or 24 V battery operation, the input voltage will be passed through so that the output voltage equals the input voltage.

Proceed as follows when you connect the refrigerator to the AC supply:

- Attach the rectifier on the back of the refrigerator.

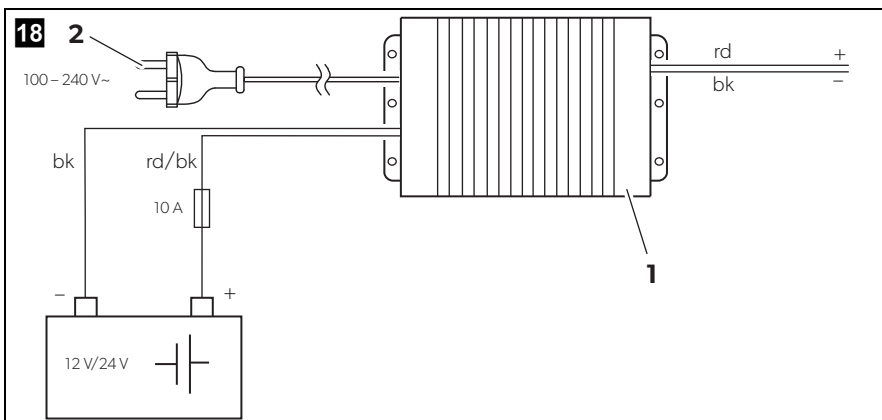

- Connect the rectifier as shown in fig. **18**.
- Connect the refrigerator to the rectifier (fig. **18** 1):
 - Red cable (rd): positive battery terminal
 - Black cable (bk): negative battery terminal
- Plug the connector (fig. **18** 2) into the AC socket.

8 Using the refrigerator

The refrigerator conserves fresh foodstuffs. The freezer compartment conserves frozen foodstuffs and freezes fresh foodstuffs.



NOTICE! DANGER OF DAMAGE

- Do not place any electrical devices inside the cooler. The only exceptions are devices approved for the purpose by the manufacturer.
- Ensure that food or liquids in glass containers are not excessively refrigerated. Liquids expand when they freeze and can therefore destroy glass containers.
- Food may only be stored in its original packaging or in suitable containers.
- Make sure that you only put items in the cooler which may be kept at the selected temperature.



NOTE

- Before starting your new refrigerator for the first time, you should clean it inside and outside with a damp cloth for hygienic reasons (please also refer to the chapter “Cleaning and maintenance” on page 34).
- Do not use force to press the flap of the freezer.
- Do not pull out the dividing wall if there is ice in the freezer.
- Do not remove the control panel membrane when operating the refrigerator.

8.1 Energy saving tips

- Choose a well ventilated location which is protected from direct sunlight.
- Allow hot food to cool down first before you put it in the refrigerator.
- Do not open the refrigerator more often than necessary. If the door is left open for more than 5 minutes, the light starts to flash.
- Do not leave the door open for longer than necessary.
- Defrost your refrigerator as soon as a layer of ice forms.
- Avoid unnecessarily low temperature settings.
- Clean dust and dirt from the condenser at regular intervals.

8.2 Switching on the refrigerator



- Switch the refrigerator on by pressing the  button.



NOTE

After switching on, the refrigerator needs some time before the compressor starts up.

8.3 Setting the temperature

- Press the  button repeatedly until the desired temperature level is set. The lower/largest LED is the coldest setting. The upper/smallest LED is the warmest setting. To switch from the coldest level to the warmest level press the  button again.



NOTE

The cooling performance can be affected by:

- The ambient temperature
- The amount of food to be conserved
- The frequency with which the door is opened.

If the ambient temperature is at 16 °C (61 °F) to 20 °C (68 °F), set the refrigerator to at least level 2.



8.4 Setting the fast cooling function (CRX50, CRX65, CRX80 only)



NOTICE! DANGER OF DAMAGE



- Only use the fast-cooling function when the removable freezer compartment is **not** being used. Otherwise there is a risk that the freezer compartment becomes too cold and condensate cannot be prevented from forming on the outside of the refrigerator. The energy consumption will also increase dramatically.
- Note that bottles and other containers can burst when frozen.
- Note that it is difficult to open the refrigerator directly after closing it.

The option of operating the refrigerator using a fast-cooling function allows temperatures suitable for freezing foods to be reached.

- Press the  button longer than 3 seconds.
- ✓ The LED above the  button lights up.
- Press the  button again longer than 3 seconds to operate the refrigerator in normal mode.

8.5 Setting the winter mode (CRX110ACDC, CRX140ACDC only)

The winter mode ensures optimum operation at ambient temperature of below 16 °C (61 °F):

- ▶ Press the  button longer than 3 seconds.
- ✓ The refrigerator switches to winter mode and the LED lights up above the  button.
- ▶ Press the  button again longer than 3 seconds to operate the refrigerator in normal mode.

8.6 Conserving foodstuffs



NOTICE! DANGER OF DAMAGE

- Do not conserve **warm** foodstuffs in the refrigerator.
- Do not place glass containers containing liquid in the freezer compartment.



NOTE

Food which can easily absorb tastes and odours, as well as liquids and products with a high alcohol content, should be conserved in air-tight containers.

You can conserve foodstuffs in the refrigerator. The time for which the food can be conserved in this way is usually stated on the package.

The refrigerator is divided in different zones with different temperatures:

- The colder zones are immediately above the drawers for fruit and vegetables, near the back wall.
- Observe the temperature information and best before date on the food packaging.
- Observe the following when using the refrigerator:
 - Never re-freeze products which have started defrosting or have been defrosted; consume them as soon as possible.
 - Wrap food in aluminium foil or cling film and shut in a suitable box with a lid. This ensures that aromas, the shape and the freshness will be better conserved.

8.7 Defrosting the freezer



NOTICE! DANGER OF DAMAGE

Never use mechanical tools to remove ice or to loosen objects stuck to the device. The only exceptions are devices approved for the purpose by the manufacturer.

This is how to defrost the refrigerator:

- Empty the contents.
- If necessary, put them in another cooling device to keep them chilled.
- Press the ① button until the refrigerator switches off.
- Close the door properly.

8.8 Releasing the lock



NOTICE! DANGER OF DAMAGE

Only adjust the locking mechanism when the door is open. If you use it with the door closed, you will damage the device.

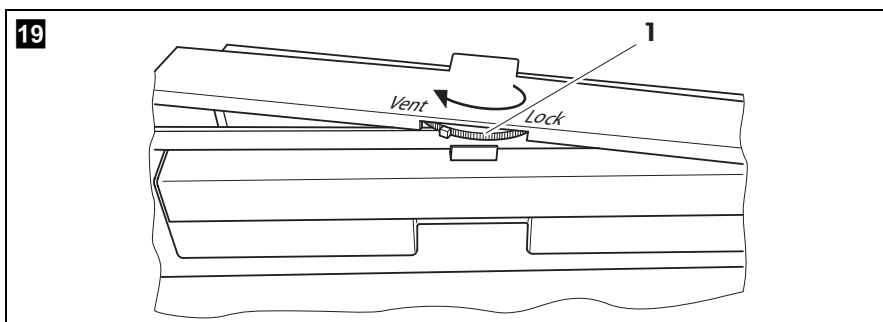

The refrigerator has a locking mechanism (fig. 19 1) which is also used to protect it during transport. The following settings are possible:

- **Lock** (turn wheel to the Right end stop): the door is locked and secured.
To open the door, lift the handle up and open it.
- **Vent** (turn wheel to the Left end stop): The door is slightly open, but fixed in position.
Use this position if you are not going to use the unit for a long time.

8.9 Switching off and storing the refrigerator

If you do not intend to use the refrigerator for a long time, proceed as follows:

- Press the  button until the refrigerator switches off.
- Disconnect the connection cable from the battery or disconnect the plug on the AC cable plug from the rectifier.
- Clean the refrigerator (see chapter “Cleaning and maintenance” on page 34).
- Turn the locking wheel (fig. **19** 1) to the Right end stop (“Vent”).
- Close the door until it latches in.
- ✓ The door stays open thus preventing smells from arising.

8.10 Change the fuse (CRX50ACDC, CRX65ACDC, CRX80ACDC, CRX110ACDC, CRX140ACDC only)

If the fuse in the AC socket is faulty, it can be replaced.

- Lever the fuse compartment (fig. **17** 2) open with a screwdriver.
- Replace the fuse (250 V/4 A).
- Close the fuse compartment again.

9 Cleaning and maintenance



WARNING! Electrocuting hazard

Always disconnect the refrigerator from the mains before you clean and service it.



NOTICE! Damage hazard

- Do not use abrasive cleaning agents or hard objects during cleaning as these can damage the refrigerator.
- Never use hard or sharp tools to remove ice or to free objects frozen onto the device.
- Do not use any mechanical tools or any other tools to speed up the defrosting process.

- Clean the refrigerator regularly and as soon as it becomes dirty with a damp cloth.
- Make sure that no water drips into the seals. This can damage the electronics.
- Wipe the refrigerator dry with a cloth after cleaning.
- Check the condensate drain regularly.
Clean the condensate drain when necessary. If it is blocked the condensate collects on the bottom of the refrigerator.

10 Limited warranty

If the product does not work as it should, please contact your retailer or the manufacturer's branch in your country (see dometic.com/dealer). The warranty applicable to your product is 3 year(s).

For repair and warranty processing, please include the following documents when you send in the device:

- A copy of the receipt with purchasing date
- A reason for the claim or description of the fault

Australia only

Our goods come with guarantees that cannot be excluded under the Australian Consumer Law. You are entitled to a replacement or refund for a major failure and for compensation for any other reasonably foreseeable loss or damage. You are also entitled to have the goods repaired or replaced if the goods fail to be of acceptable quality and the failure does not amount to a major failure.

New Zealand only

This warranty policy is subject to the conditions and guarantees which are mandatory as implied by the Consumer Guarantees Act 1993(NZ).

11 Disposal



WARNING! CHILDREN BEWARE

Before disposing of your old refrigerator:

- Take off the doors.
- Leave storage surfaces in the refrigerator so that children cannot climb inside.

- Place the packaging material in the appropriate recycling waste bins wherever possible.



If you wish to finally dispose of the product, ask your local recycling centre or specialist dealer for details about how to do this in accordance with the applicable disposal regulations.

12 Troubleshooting

The significance of the red LED (fig. 6 2, page 15, fig. 7 2, page 15)

For operational faults it illuminates several times. The number of pulses depends on the type of fault.

Each flash lasts for one quarter of a second. After the series of impulses a pause follows. The sequence for the fault is repeated every four seconds.

CRX50, CRX65, CRX80

Number of flashes	Fault	Possible cause
1	Low Voltage	The supply voltage is outside of the set range.
2	Excessive fan current	The fan load on the electronics unit is more than 1 A.
	Too many start attempts	The compressor or fan has been started too often within a short period of time.
3	The motor doesn't start	The rotor is jammed. The pressure difference in the cooling system is too high (> 5 bar).
4	Speed too low	If the cooling system is overloaded, the minimum speed of the motor of 1,850 rpm cannot be maintained.
5	Overheating of the electronics unit	If the cooling system is loaded too heavily or the temperature is set too high, the electronics can overheat.
Constantly	Temperature sensor errors	Temperature sensor is defective.

CRX110, CRX140

Number of flashes	Fault	Possible cause
1	Low Voltage	The supply voltage is outside of the set range.
2	Excessive fan current	The fan load on the electronics unit is more than 1 A.
3	The motor doesn't start	The rotor is jammed. The pressure difference in the cooling system is too high (> 5 bar).
4	Speed too low	If the cooling system is overloaded, the minimum speed of the motor of 1,850 rpm cannot be maintained.

Number of flashes	Fault	Possible cause
5	Overheating of the electronics unit	If the cooling system is loaded too heavily or the temperature is set too high, the electronics can overheat.
Constantly	Temperature sensor errors	Temperature sensor is defective.

Compressor does not run (battery connection)

Problem	Possible cause	Remedy
$U_{\text{Term}} = 0 \text{ V}$	There is an interruption in the battery – electronics connection	Establish a connection
	Main switch faulty (if installed)	Replace the main switch
	Additional supply line fuse has blown (if installed)	Replace the supply line fuse
$U_{\text{Term}} \leq U_{\text{ON}}$	Battery voltage is too low	Charge the battery
Start attempt with $U_{\text{Term}} \leq U_{\text{OFF}}$	Loose cables	Establish a connection
	Poor contact (corrosion)	Establish a connection
	Battery capacity too low	Replacing the battery
Start attempt with $U_{\text{Term}} \geq U_{\text{ON}}$	Cable cross section too small	Replace the cable (fig. 14, page 24)
	Ambient temperature too high	–
	Insufficient ventilation	Move the refrigerator to another location
Start attempt with $U_{\text{Term}} \geq U_{\text{ON}}$	Condenser is dirty	Clean the condenser
	Defective compressor	Contact customer service
Electric circuit between the pins in the compressor interrupted	Defective compressor	Contact customer service

U_{Term} Voltage between the positive and negative terminals of the electronics

U_{ON} Cut-in voltage of the electronics

U_{OFF} Cut-off voltage of the electronics

Compressor is not running (connected to AC supply)

Problem	Possible cause	Remedy
No voltage	Connection supply line interrupted	Establish a connection
	Main switch faulty (if installed)	Replace the main switch
	Additional supply line fuse has blown (if installed)	Replace the supply line fuse
Voltage is present but the compressor doesn't run	Ambient temperature too high	–
	Insufficient ventilation	Move the refrigerator to another location
	Condenser is dirty	Clean the condenser
Electric circuit between the pins in the compressor interrupted	Defective compressor	Contact customer service

Poor cooling, increase in interior temperature



Problem	Possible cause	Remedy
Compressor runs for a long time/continuously	Ambient temperature too high	–
	Insufficient ventilation	Move the refrigerator to another location
	Condenser is dirty	Clean the condenser
	Faulty fan	Replace the fan
Compressor does not run often	Battery capacity exhausted	Charge the battery

Unusual noises



Problem	Possible cause	Remedy
Loud humming	A component of the refrigerant circuit cannot move freely (touching the wall)	Bend the component carefully away from the obstruction
	There is a foreign object stuck between the cooling unit and the wall	Remove the foreign object
	Fan noise	Replace the fan

13 Technical data

	CRX50	CRX65	CRX80
ACDC models:	CRX1050	CRX1065	CRX1080
DC models:	CRX0050	CRX0065	CRX0080
Refrigerator compartment storage volume:	41.2 l (1.45 cu.ft.)	50 l (1.77 cu.ft.)	70.6 l (2.49 cu.ft.)
Freezer compartment storage volume:	4.4 l (0.16 cu.ft.)	7.0 l (0.25 cu.ft.)	7.5 l (0.26 cu.ft.)
Total storage volume:	45 l (1.59 cu.ft.)	57 l (2.01 cu.ft.)	78 l (2.75 cu.ft.)
Voltage:	12 V \equiv or 24 V \equiv 100 – 240 V \sim (ACDC models only)		
Power consumption (AC) (ACDC models only):	40 W	45 W	48 W
Rated current			
12 V \equiv :	5.0 A	5.5 A	5.6 A
24 V \equiv :	2.6 A	2.8 A	2.9 A
100 V \sim (ACDC models only):	1.14 A	1.22 A	1.23 A
240 V \sim (ACDC models only):	0.53 A	0.58 A	0.56 A
Cooling temperature range			
Refrigerator:	+3 °C (37 °F) to +12 °C (54 °F)		
Freezer:	-15 °C (5 °F) to -5 °C (23 °F)		
Fast cooling (without dividing wall):	maximum -6 °C (21 °F) \pm 2 °C (36 °F)		
Climatic class:	T		
Relative humidity:	maximum 90 %		
Short-term inclination:	maximum 30°		
Max. pressure:	LP 11 bar/HP 25 bar		
Propellant:	C ₅ H ₁₀		
Refrigerant:	R134a		
Refrigerant quantity:	38 g (1.34 oz.)	42 g (1.48 oz.)	48 g (1.69 oz.)
CO ₂ equivalent:	0.054 t (119 lbs)	0.060 t (132.3 lbs)	0.069 t (152.1 lbs)

	CRX50	CRX65	CRX80
Global warming potential (GWP):	1430		
Dimensions:	fig. 20 , page 42	fig. 21 , page 42	fig. 22 , page 42
Weight			
ACDC models:	17.4 kg (38.36 lbs)	19.8 kg (43.65 lbs)	22 kg (48.50 lbs)
DC models:	17 kg (37.48 lbs)	19 kg (41.89 lbs)	21 kg (46.30 lbs)
Inspection/certification:	  		

	CRX110	CRX140
ACDC models:	CRX1110	CRX1140
DC models:	CRX0110	
Refrigerator compartment storage volume:	98 l (3.46 cu.ft.)	124 l (4.38 cu.ft.)
Freezer compartment storage volume:	9.5 l (0.34 cu.ft.)	11 l (0.39 cu.ft.)
Total storage volume:	107.5 l (3.80 cu.ft.)	135 l (4.77 cu.ft.)
Voltage:	12 V \equiv or 24 V \equiv 100 – 240 V \sim (ACDC models only)	
Power consumption (AC) (ACDC models only):	50 W	65 W
Rated current		
12 V \equiv :	6.2 A	7.7 A
24 V \equiv :	3.0 A	3.6 A
100 V \sim (ACDC models only):	0.82 A	0.95 A
240 V \sim (ACDC models only):	0.34 A	0.4 A
Cooling temperature range		
Refrigerator:	+3 °C (37 °F) to +12 °C (54 °F)	
Freezer:	-18 °C (0 °F) to -6 °C (21 °F)	

	CRX110	CRX140
Winter mode setting (ACDC models only):	–	5 W heating, off-cycle
Climatic class:	T	
Relative humidity:	Max. 90 %	
Short-term inclination:	maximum 30°	
Max. pressure:	LP 11 bar/HP 25 bar	
Propellant:	C ₅ H ₁₀	
Refrigerant:	R134a	
Refrigerant quantity:	47 g (1.66 oz.)	50 g (1.76 oz.)
CO ₂ equivalent:	0.067 t (147.7 lbs)	0.072 t (158.73 lbs)
Global warming potential (GWP):	1430	
Dimensions:	fig. 23 , page 43	fig. 24 , page 43
Weight		
ACDC models:	29.3 kg (64.60 lbs)	32.0 kg (70.55 lbs)
DC models:	27.6 kg (60.85 lbs)	30.6 kg (67.46 lbs)
Inspection/certification:	  	

Contains fluorinated greenhouse gases

Hermetically sealed equipment

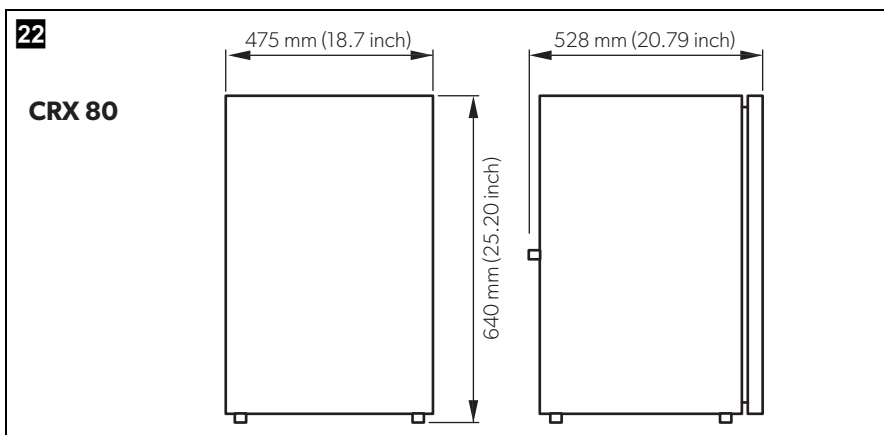
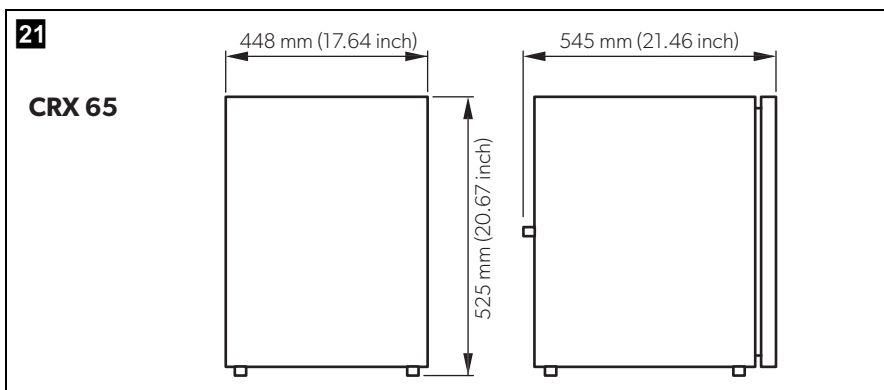
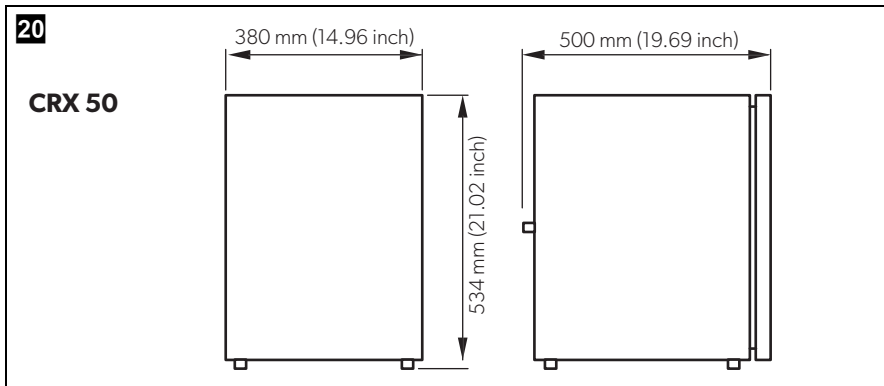

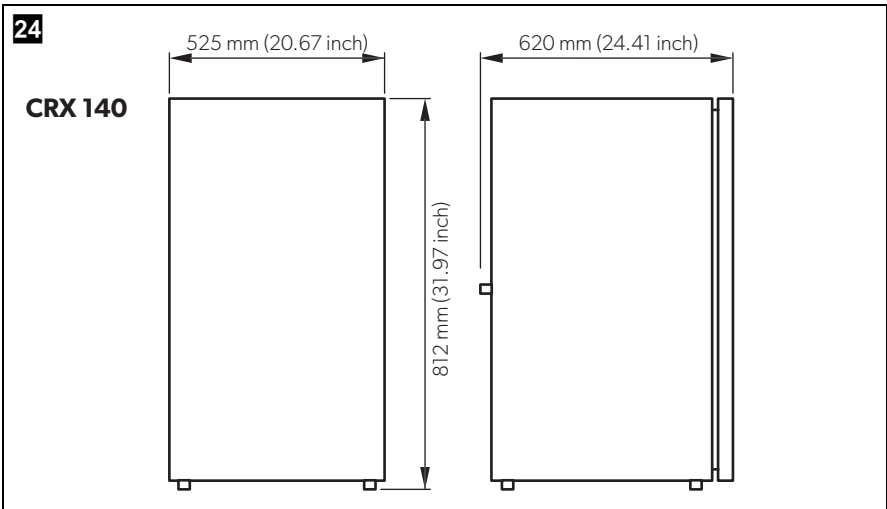
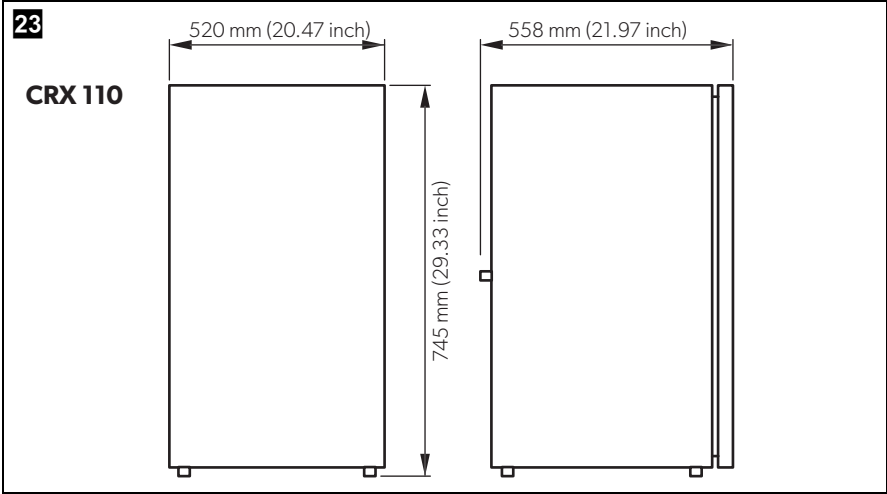

Mobile living made easy.



dometic.com

**YOUR LOCAL
DEALER**

dometic.com/dealer

**YOUR LOCAL
SUPPORT**

dometic.com/contact

**YOUR LOCAL
SALES OFFICE**

dometic.com/sales-offices

A complete list of Dometic companies, which comprise the Dometic Group, can be found in the public filings of:
DOMETIC GROUP AB Hemvärnsgatan 15 SE-17154 Solna Sweden