



Combi (E)

GB Operating instructions

Page 2

To be kept in the vehicle!



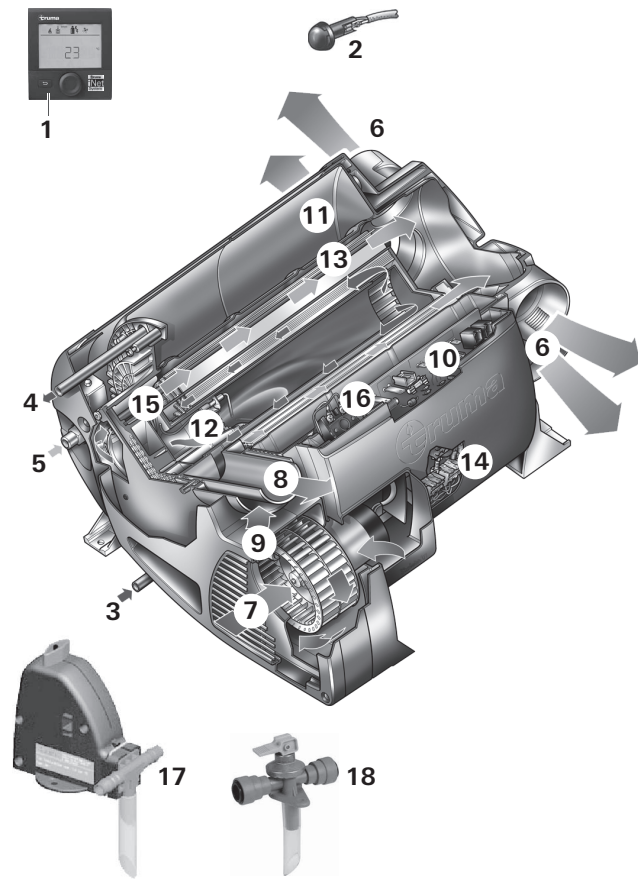

- 1 Control panel, digital or analogue (no picture)
- 2 Room temperature sensor
- 3 Cold water connection
- 4 Hot water connection
- 5 Gas connection
- 6 Warm air outlets
- 7 Circulated air intake
- 8 Exhaust gas discharge
- 9 Combustion air infeed
- 10 Electronic control unit
- 11 Water container (10 litres)
- 12 Burner
- 13 Heat exchanger
- 14 Power electronics
- 15 Heating elements 230 V ~
- 16 Overheating switch 230 V ~
- 17 FrostControl (safety/drain valve – UK version optional)
- 18 Safety/drain valve (UK version)

Figure 1

Inhaltsverzeichnis

Symbols used	2
Intended use	2
Safety instructions	3
Function description (Combi)	5
Function description (Combi E)	5

Operating instructions

Control panels	6
Room temperature sensor	6
Safety/drain valve	6
A. FrostControl	6
B. Safety/drain valve	6
Filling the boiler	7
Draining the boiler	7
Start-up	7
Switching off	7
Maintenance	7
Fuses	8
Fuse 12 V =	8
230 V ~ fuse (Combi E)	8
230 V ~ overheating protection (Combi E)	8
Technical data	8
Dimensions	9
Disposal	9
Faults	9
Troubleshooting guide (water supply)	9
Accessories	10
Manufacturer's Warranty (European Union)	10

Symbols used



Symbol indicates possible hazards.



Note containing information and tips.

Intended use

The liquid gas heater Combi is a warm-air heater with integrated hot water boiler (10 litre volume). This unit was designed for installation in motor homes (vehicle class M1) and caravans (vehicle class O).

It must not be installed in buses (vehicle classes M2 and M3) or in vehicles for transporting hazardous goods.

What must I do if I smell gas?

- Extinguish all naked flames
- Open windows and doors
- Close all quick-acting valves and gas cylinders
- Do not smoke
- Do not operate any electrical switches
- Have the entire gas system checked by an expert.

A safe operating environment

- The unit may be operated only with appropriate Truma control panels and accessories.
- Danger of toxic exhaust fumes. The heater's exhaust can be toxic in enclosed spaces (e.g. garages, workshops). If the vehicle is parked in closed rooms:
 - Shut off the fuel supply to the heater
 - Deactivate the time switch
 - Switch off the heater at the control panel.
- If the cowl has been placed near or directly beneath an opening window, the appliance must be equipped with an automatic shut-off device in order to prevent operation with the window open.
- Heat-sensitive objects (e.g. spray cans) or flammable materials/ liquids must not be stored in the same compartment where the appliance is installed because, under certain conditions, this area may be subject to elevated temperatures.
- Keep flammable materials away from the area in front of the warm air outlets. Never block the warm air outlets.
- The openings for circulated air intake, the installation compartment and the space around the unit must be kept free of obstacles so that the unit does not overheat.
- Keep the cowl for the exhaust duct and combustion air intake free of contamination (slush, ice, leaves etc.) at all times.
- Danger from hot surfaces and exhaust gas. Do not touch the area around the wall cowl and do not lean any objects against the wall cowl or the vehicle.

- The operator is responsible for the water with which the Combi boiler is filled and for its quality.
- The vehicle owner is responsible for correct operation of the appliance.
- The installer or vehicle owner must affix the supplied yellow sticker with the warning information in a location in the vehicle where it is clearly visible to all users (e.g. the wardrobe door). Missing stickers can be requested from Truma.
- Liquid gas systems must comply with the technical and administrative regulations of the respective country of use (e.g. EN 1949 for vehicles in Europe). The national legislation and regulations (e.g. DVGW Work Sheet G 607 for vehicles in Germany) must be observed.
- The vehicle owner must arrange for the gas system to be tested (in Germany every 2 years) by a liquid gas expert (DVFG, TÜV, DEKRA). The test must be confirmed on the respective test certificate (G 607).
- Pressure regulating devices and hoses must be replaced with new ones no more than 10 years after their date of manufacture (every 8 years if used commercially).
- Inspect hose lines regularly and have them replaced if they are broken.
- If the heater is not being used, always drain off the water if there is a risk of frost. No claims may be made under the warranty for damage caused by frost.

Safe operation

- The use of upright gas cylinders from which gas is **taken in the gas phase** is mandatory for the operation of gas pressure regulation systems, gas equipment and gas systems. Gas cylinders from which gas is taken in the liquid phase (e. g. for fork lifts) must not be used, since they would result in damage to the gas system.
- The operating pressure of the gas supply (30 mbar) and of the appliance (see type plate) must be the same.

- In Germany, only pressure regulating equipment that complies with DIN EN 16129 (in vehicles) with a fixed output pressure of 30 mbar may be used for the gas system. The flow rate of the pressure regulating equipment must correspond to at least the maximum consumption of all devices installed by the system manufacturer.
- We recommend the Truma MonoControl CS gas pressure regulation system for vehicles and the Truma DuoComfort / DuoControl CS gas pressure regulation system for dual-cylinder gas systems.
- At temperatures of around 0 °C and below, the gas pressure regulation system or the changeover valve should be operated with the EisEx regulator heater.
- Suitable hoses that meet national regulations must always be used in the respective country for which the equipment is destined.
- Ensure that the inside of the vehicle is sufficiently ventilated. When the unit is started up, there may be some smoke and/or smell due to dust or dirt. Especially if it has not been used for a long time.
- This appliance can be used by children aged 8 and over, as well as by persons with reduced physical, sensory or mental capabilities or with a lack of experience and knowledge, provided that they are supervised or have been instructed on how to use the appliance safely and that they understand the resulting risks. Children must not be allowed to play with the appliance.
- The integrity and tight fit of the exhaust double duct must be checked regularly, particularly at the end of long trips. Also check the mounting of the unit and the cowl.

Operation while driving

- Directive UN ECE R 122 stipulates that a safety shut-off device is required if motor homes and caravans are heated while driving. The Truma MonoControl CS gas pressure regulation system satisfies this requirement. Throughout Europe, a type-tested liquefied gas heating system may be used while driving (according to the directive UN ECE R 122) if the system includes a gas pressure regulator with an appropriately configured gas installation. National regulations and rules must be followed.
 - If **no** safety shut-off device (e.g. as contained within the Truma MonoControl CS gas pressure regulation system) has been installed, the gas cylinder must be closed when driving and **information signs** must be attached in the gas cylinder protection box and in the vicinity of the control panel.
 - Liquid gas equipment must not be used when refuelling, in multi-storey car parks, in garages or on ferries.
 - To prevent damage to the appliance from spray water, such as when cleaning the vehicle, do not spray water directly into the cowl.
- ## Troubleshooting
- If you notice unusual noises or smells, close off the gas supply and switch off the Combi.
 - Danger of fire / explosion if you attempt to use a Combi that has been damaged by flooding or if the vehicle has been involved in an accident. A damaged Combi must be repaired by an expert or be replaced.
 - Have faults repaired by an expert without delay.
 - Only carry out repairs yourself if the solution is described in the troubleshooting guide of this manual.
 - Following a deflagration (backfire), have the appliance and the exhaust duct checked by an expert.

Maintenance / Repairs / Cleaning

- The unit may only be repaired and cleaned by an expert.
- Maintenance, repairs and cleaning must not be done by children.
- Guarantee claims, warranty claims and acceptance of liability will be ruled out in the event of the following:
 - Modifications to the appliance (including accessories),
 - Modifications to the exhaust duct and the cowl,
 - Use of replacement and accessory parts other than original Truma parts,
 - Failure to follow the installation and operating instructions.

The appliance's operating permit, and consequently also the vehicle's operating permit in some countries, are also rendered void.

- With a new Combi or if the appliance has not been used for some time, thoroughly rinse all hot/cold water hoses with drinking water before use.

Function description (Combi)

The liquid gas heater Combi is a warm-air heater with integrated hot water boiler (10 litre volume). The burner is fan-assisted, which ensures that operation is problem-free, even when on the move.

In **heating and hot water mode** the heater can be used to heat the room and heat water up at the same time. If only hot water is required, select **hot water mode**.

- In **hot water mode**, the water is heated at the lowest burner setting. Once the water temperature has been reached, the burner switches off.
- In **heating and hot water mode**, the unit automatically selects the required operating level according to the temperature difference between the temperature set on the control panel and the current room temperature. If the boiler has been filled, the water is automatically heated as well. The water temperature depends on the selected operating mode and the heater output.

At a temperature of approximately 3 °C at the automatic FrostControl safety/drain valve, the valve will open and drain the boiler.

Function description (Combi E)

The liquid gas heater Combi E is a warm-air heater with integrated hot water boiler (10 litres volume). The burner is fan-assisted, which ensures that operation is problem-free, even when on the move. The unit also has heating elements for electrical operation.

In **heating and hot water mode** the heater can be used to heat the room and heat water up at the same time. If only hot water is required, select **hot water mode**.

At a temperature of approximately 3 °C at the automatic FrostControl safety/drain valve, the valve will open and drain the boiler.

3 different options are available for operating the unit:

- **gas mode** only
Propane / Butane for autonomous use
- **electrical mode** only
230 V ~ for stationary use on camp sites
- or gas and electrical mode – **mixed mode**
Only possible in winter.

Heating and hot water mode

In **heating and hot water mode**, the unit automatically selects the required operating level according to the temperature difference between the temperature set on the control panel and the current room temperature. If the boiler has been filled, the water is automatically heated as well. The water temperature depends on the selected operating mode and the heater output.

All 3 energy selection options can be used for winter deployment.

- In **gas mode** the unit automatically selects the operating level that is required.
- In **electrical mode** output of 900 W (3.9 A) or 1800 W (7.8 A) can be manually preselected in accordance with the fuse protection at the camp site.

If more output is required (e.g. heating up or low outside temperatures) gas or mixed mode should be selected so that enough heating power is always available.
- In **mixed mode** 230 V ~ electrical mode is preferred if the power requirement is low (e.g. for maintaining the room temperature). The gas burner is not enabled until the power requirement is higher, and is the first to switch off during heat-up operations.

Hot water mode (with filled boiler only)

Gas mode or 230 V ~ electrical mode is used to generate hot water. The water temperature can be set to 40 °C or 60 °C.

- In **gas mode** the water is heated at the lowest burner setting. Once the water temperature has been reached, the burner switches off.
- In **electrical mode** output of 900 W (3.9 A) or 1800 W (7.8 A) can be manually selected in accordance with the fuse protection at the camp site.

 **Mixed mode** is not possible. With this setting the unit automatically selects electrical mode. The gas burner is not enabled.

Operating instructions

Read the safety instructions and operating instructions carefully before starting the unit.

i Operating instructions can be viewed in offline mode with a mobile device and the Truma App. Download the operating instructions when you have a WiFi connection and save them on your mobile device.

Before initial use, be sure to flush the entire water supply thoroughly with clear water.

i The materials of the appliance that come into contact with water are drinking water safe (see manufacturer declaration: www.truma.com – Manufacturer Declaration).

Control panels

The control panels are described in separate operating instructions.

Room temperature sensor

To measure the room temperature, an external room temperature sensor (2) is located in the vehicle. The position of the sensor is determined by the vehicle manufacturer depending on the vehicle model. More information can be found in the operating instructions for your vehicle.

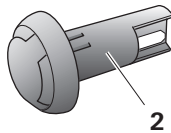

Figure 2

The temperature setting on the control panel depends on personal heating requirements and the design of the vehicle, and must be determined individually.

Safety/drain valve

A. FrostControl

(Safety/drain valve with integral frost protection / optional in UK version)

FrostControl is a currentless safety/drain valve. When there is a danger of frost, it automatically drains the contents of the boiler through a drainage socket. If excessive pressure is present in the system, pressure will be automatically intermittently equalized through the pressure relief valve.

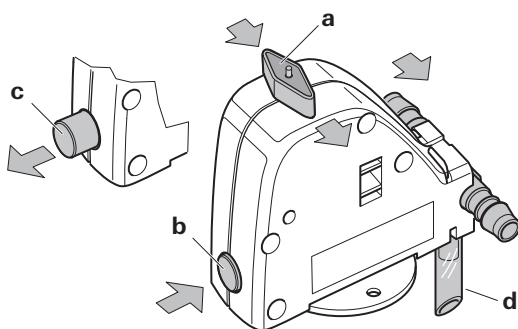

Figure 3

a = rotary switch position "On"
b = pushbutton position "Closed"
c = pushbutton position "Drain"
d = drainage socket (led outside through floor of vehicle)

Opening the safety/drain valve

– Turn the rotary switch by 180° until it engages, whereby the pushbutton pops out (position c). The water from the boiler drains through the drainage socket (d).

The FrostControl drainage socket (d) must be free of contamination (slush, ice, leaves, etc.) at all times so the water can drain out easily! **No claims may be made under the warranty for damage caused by frost.**

Closing the safety/drain valve

– Check whether the rotary switch is set to "On" (position a), i.e. parallel to the water connection and engaged.

– Close the safety/drain valve by pressing the pushbutton. The pushbutton must engage in position (b) "closed".

Only when the temperature at the safety/drain valve is above approx. 7 °C can it be closed manually with the pushbutton (position b) and the boiler filled.

Truma supplies a heating element (part no. 70070-01) as an accessory, which is inserted into the FrostControl and fixed in place with a retaining bracket. This heating element heats the FrostControl to approx. 10 °C when the Combi is switched on. This means that the boiler can be filled sooner, irrespective of the temperature in the installation compartment.

Automatic opening of the safety/drain valve

If the temperature at the safety/drain valve is below about 3 °C, it will open automatically and the pushbutton pops out (position c). The water from the boiler drains through the drainage socket (d).

B. Safety/drain valve

(Safety/drain valve without frost protection / standard in UK version)

The safety/drain valve automatically equalises the pressure in the event of overpressure in the system. When this occurs, the water is drained to the outside in intermittent bursts via a drainage socket.

i This safety/drain valve does not protect the water container from **frost damage**.

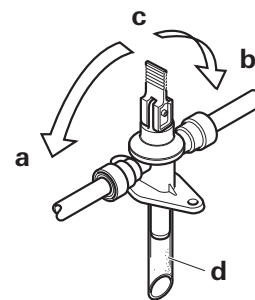

Figure 4

a = Lever in position "Operational – closed"
b = Lever in position "Operational – closed"
c = Lever in position "Drain"
d = Drainage socket (led outside through floor of vehicle)

Opening the safety/drain valve

– Move lever to position (c) – vertical. The water from the boiler drains through the drainage socket (d).

The drainage socket (d) of the safety/drain valve must be free of contamination (slush, ice, leaves, etc.) at all times so the water can drain out easily! **No claims may be made under the warranty for damage caused by frost!**

Closing the safety/drain valve

– Move lever to position (a) or (b) – horizontal.

Filling the boiler

Check whether the safety/drain valve is closed (see "Closing the safety/drain valve").

 When the temperature at FrostControl is below approx. 7 °C, **first** switch on the heater to warm the installation compartment and FrostControl. After several minutes, when the temperature at FrostControl is above 7 °C, the safety/drain valve can be closed.

- Switch on the power for the pump assembly (main switch or pump switch).
- Open hot water taps in the kitchen and bathroom (set pre-selecting mixing taps or single-lever fittings to "hot"). Leave the valves open until the boiler has been filled by displacing the air and water is flowing without interruption.

 If only the cold water system is being operated without the boiler, the boiler also fills up with water. To avoid frost damage, the boiler must be drained via the safety/drain valve, even if it was not operated.

In the event of frost, filling may be prevented by frozen residual water. The boiler can be thawed by turning it on briefly (no more than 2 minutes). Frozen lines can be thawed by heating the interior.

 If the boiler is connected to a central water supply (rural or urban connection), a pressure reducer must be used, which will prevent pressures higher than 2.8 bar from occurring.

Draining the boiler

 The boiler must be drained if the motor home / caravan is not being used during the frosty period.

- Switch off the power to the pump assembly (main switch or pump switch).
- Open hot water taps in kitchen and bathroom.

 In order to check the water that is flowing out, place an appropriate container (capacity 10 litres) beneath the drainage socket (d) of the safety/drain valve.

- Open safety/drain valve (see "Opening the safety/drain valve").

The boiler will now be drained directly to the outside via the safety/drain valve. Check whether all of the water in the boiler (10 litres) has been drained into the container via the safety/drain valve.

No claims may be made under the warranty for damage caused by frost.

Start-up

Combi

The interior can be heated either with or without water, depending on the setting.

Combi E

The interior can be heated in gas, electrical or mixed mode, either with or without water, depending on the setting.

Check whether the power supply fuse protection at the camp site is adequate for the 900 W (3.9 A) or 1800 W (7.8 A) that have been selected using the power selector switch.

The cable drum must be fully unwound in order to prevent the power cable from overheating.

- Check to make sure the cowl is unobstructed. Be sure to remove any covers that may be present.
- Open the gas cylinder and the quick-acting valve in the gas supply line.
- Fill boiler with water if necessary (see "Filling the boiler").
- Switch on the unit on the control panel.

Switching off

- Switch the heater off on the control panel.
- The switch-off procedure may be delayed by several minutes because of internal heater operations.

Always drain water contents if there is a risk of frost!

If the appliance is not used for a long period, close the quick-acting valve in the gas supply line and the gas cylinder.

Maintenance

Only original Truma parts may be used for maintenance and repair work.

- Clean the compartment where the unit is installed at least once annually.
- Have an expert check the unit for dirt and clean it if necessary.
- The safety/drain valve must be operated regularly (at least twice annually) to remove limescale deposits and to be certain that it is not blocked.

We recommend the use of suitable commercially available products to clean, sterilise and maintain the boiler. Products containing chlorine are not suitable.

The effectiveness of the use of chemicals to combat micro-organisms in the appliance can be increased by heating the water in the boiler to 70 °C at regular intervals.

Combi E only

- Select "Gas mode".
- Set the water temperature to 60 °C.
- Switch on the appliance.

 Once the water in the boiler has reached a temperature of 60 °C, the burner will switch off. The appliance must stay switched on for at least 30 minutes and no hot water may be removed. The residual heat in the heat exchanger will heat the water up to 70 °C.

Fuses

Fuse 12 V \equiv

The fuse is in the electronics beneath the connection cover. Always replace the fuse of the unit with an identical fuse.

Appliance fuse: 10 A – slow-acting – 5 x 20 mm (T 10 A)

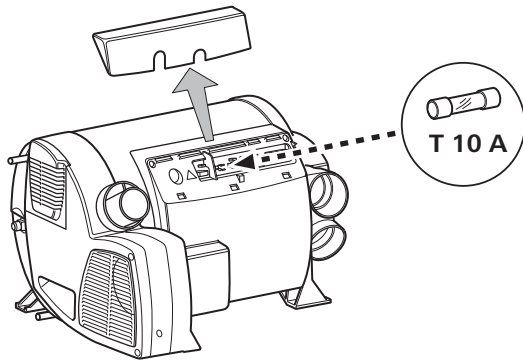



Figure 5

230 V \sim fuse (Combi E)

The fuse and the power supply lines must only be replaced by an expert!

 The unit must be disconnected from the mains (all poles) before opening the electronic housing lid.

The fuse is in the power electronics (14) beneath the electronic housing lid.

This fine fuse must always be replaced with a fuse of the same type: 10 A, slow-acting, interrupting capacity "H".

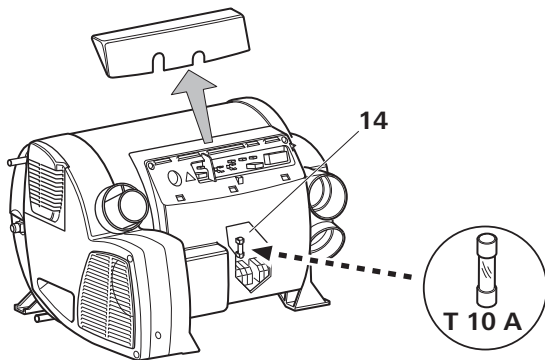

Figure 6

230 V \sim overheating protection (Combi E)

The 230 V \sim heating facility has a mechanical overheating switch. If the 12 V \equiv power supply is interrupted during operation or during the after-run period, for example, the temperatures within the unit could activate the overheating protection.

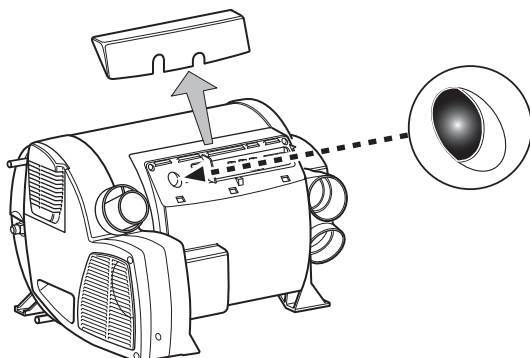

Figure 7

To reset the overheating protection, allow heater to cool, remove connection cover and press red reset button.

Technical data

determined in accordance with EN 624 or Truma test conditions

Device category

I₃ B/P in accordance with EN 437

Type of gas

Liquid gas (propane / butane)

Operating pressure

30 mbar (see type plate)

Water capacity

10 litres

Heating time from approx. 15 °C to approx. 60 °C

Boiler approx. 20 minutes (measured according to EN 15033)

Heater + boiler approx. 80 min.

Pump pressure

max. 2.8 bar

System pressure

max. 4.5 bar

Rated thermal output (automatic operating levels)

Gas mode

Combi 2 E*: 2000 W

Combi 4 (E)*: 2000 W / 4000 W

Combi 6 (E)*: 2000 W / 4000 W / 6000 W

Electrical mode

Combi 2 E* / Combi 4 E* / Combi 6 E*: 900 W / 1800 W

Mixed mode (gas and electrical)

Combi 2 E* / Combi 4 E*: max. 3800 W

Combi 6 E*: max. 5800 W

Gas consumption

Combi 2 E*: 160 g/h

Combi 4 (E)*: 160 – 320 g/h

Combi 6 (E)*: 160 – 480 g/h

Standby heat requirement (all units)

Gas mode 5.2 g/h

Destination countries

Combi 2 E*: GB, IE

Combi 4 (E)* / Combi 6 (E)*:

DE, AT, CH, DK, FI, NL, NO, SE, SK, CZ, CY, BE, IT, PT, RO, GR, IE, LU, IS, PL, EE, LT, LV, MT, SI, HU, ES, FR, GB, BG, RU

Air delivery volume (free-blowing without warm air duct)

Combi 2 E* /

Combi 4 (E)*: With 3 warm air outlets max. 249 m³/h

With 4 warm air outlets max. 287 m³/h

Combi 6 (E)*: With 4 warm air outlets max. 287 m³/h

Power consumption at 12 V \equiv

Heater + boiler

Combi 2 E* /

Combi 4 (E)*: Max. 5.6 A for short periods

(average power consumption approx. 1.1 A)

Combi 6 (E)*: Max. 5.6 A for short periods

(average power consumption approx. 1.3 A)

Boiler heating maximum 0.4 A

Stand-by approx. 0.001 A

Heating element – FrostControl (optional): maximum 0.4 A

Power consumption at 230 V \sim

Combi 2 E* / Combi 4 E* / Combi 6 E*

3.9 A (900 W) or 7.8 A (1800 W)

Protection class

IP 21

Weight (without water)

Heater: 15.1 kg

Heater with

peripheral devices: 15.6 kg

CE product ID number

Combi 2 E*: CE-0085CN0021

Combi 4 (E)* / Combi 6 (E)*: CE-0085BS0085

* (UK) CP plus ready



Dimensions

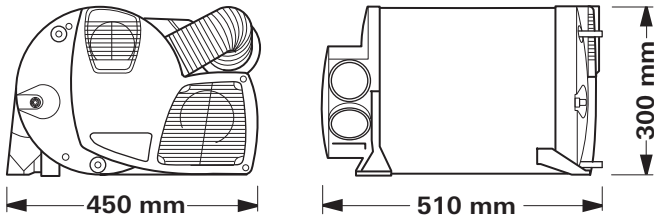

Figure 8

Subject to technical changes.

Disposal

The appliance must be disposed of in accordance with the administrative regulations of the respective country in which it is used. National regulations and laws (in Germany for example the End-of-Life Vehicle Regulation) must be observed.

Faults

Faults – Heater

Descriptions of possible fault causes and a troubleshooting guide can be found in the operating instructions for the control panel that is installed.

Faults – Water supply

Possible fault causes and a troubleshooting guide – See “Troubleshooting guide (water supply)”.

Troubleshooting guide (water supply)

Fault	Cause / Remedy
Water taking an extremely long time to heat up.	Water container furred. / Descale water system (see maintenance).
Water running away – boiler cannot be filled.	Safety/drain valve open. / Close safety/drain valve.
Boiler cannot be drained, even though the safety/drain valve is open.	Safety/drain valve drainage socket blocked. / Check opening for soiling (slush, ice, leaves etc.) and remove if necessary.
Water dripping/flowing from drainage socket of safety/drain valve.	Water pressure too high. / Check pump pressure (max. 2.8 bar). If the boiler is connected to a central water supply (rural or urban connection), a pressure reducer must be used that will prevent pressures higher than 2.8 bar from occurring.
After the heater has been switched off, the FrostControl opens.	At temperatures of less than approx. 3 °C the FrostControl opens automatically / Switch heater on / Without heater operation the FrostControl cannot be closed again until the temperature reaches approx. 7 °C / Use heating element for FrostControl.
The FrostControl can no longer be closed.	Temperature at FrostControl less than approx. 7 °C / Switch heater on / Without heater operation the FrostControl cannot be closed again until the temperature reaches approx. 7 °C. Rotary switch is not set to “Operation”. / Turn the rotary switch of the FrostControl to “Operation”, then press the pushbutton until it engages.

If these actions do not remedy the problem, please contact Truma Service.

Accessories

Truma CP plus

Truma CP plus digital control panel with automatic air conditioning system for the iNet-capable Truma heaters Combi and Truma air conditioning systems Aventa eco, Aventa comfort (from serial number 24084022 – 04/2013), Saphir comfort RC and Saphir compact (from serial number 23091001 – 04/2012)

- The automatic air conditioning system function automatically controls the heater and the air conditioning system until the required temperature is reached in the vehicle.
- With the Truma iNet Box extension, all TIN-Bus-capable Truma appliances can also be controlled via the Truma App.



Figure 9

Truma iNet Box

The Truma iNet Box for simple networking and control of Truma appliances with a smartphone or tablet computer using the app.

- Simple installation and start-up via the Truma App
- Can be extended with the update function, which ensures that it is always up to date



Figure 10

Truma CP E classic / Truma CP classic

Analogue control panels Truma CP E classic (power selector switch – Fig. 11) and Truma CP classic (control panel – Fig. 12).



Fig. 11

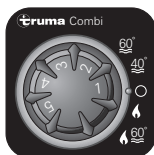

Fig. 12

Heating element for FrostControl

Heating element with 1.5 m connector cable and retaining bracket.

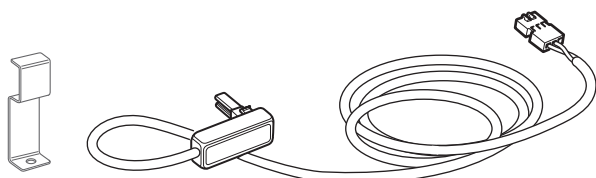

Fig. 13

Other accessories (not illustrated) for control panels

- Cable available in different lengths

Manufacturer's Warranty (European Union)

1. Scope of Manufacturer's Warranty

As the Manufacturer of the unit, Truma undertakes a warranty towards the Consumer that covers any material and/or manufacturing defects of the unit.

This Warranty is applicable in EU member states as well as in Iceland, Norway, Switzerland and Turkey. A Consumer is the natural person who was the first one to purchase the unit from the Manufacturer, OEM or dealer and who neither resold the unit in a commercial or self-employed professional capacity nor did he or she install it for a third party in such a capacity.

The Manufacturer's Warranty covers any of the aforementioned defects that occur within 24 months upon concluding the purchase agreement between the seller and the Consumer. The Manufacturer or an authorised service partner undertakes to remedy such defects through subsequent fulfilment, i.e. at its discretion either by repairing or replacing the defective item. Any defective parts shall become the property of the Manufacturer or the authorised service partner. If the unit is no longer manufactured at the time of defect notification and if replacement delivery has been opted for, then the Manufacturer may deliver a similar product.

If the Manufacturer remedies a defect under its warranty commitment, the term of the Warranty shall not recommence anew with regard to the repaired or replaced parts; rather, the original warranty period shall continue to be applicable to the unit. Only the Manufacturer itself and an authorised service partner shall be entitled to conduct a warranty job. Any costs that occur in the event of a warranty claim shall be settled directly between the authorised service partner and the Manufacturer. The Warranty does not cover additional costs arising from complicated removal or installation jobs on the unit (e.g. dismantling of furnishings or parts of the vehicle body), and neither does it cover travel expenses incurred by the authorised service partner or the Manufacturer.

No further-reaching claims shall be permitted, especially damage claims presented by the Consumer or third parties. This provision shall not affect the validity of the German Product Liability Act (Produkthaftungsgesetz).

Neither does the voluntary Manufacturer's Warranty affect the Consumer's legally applicable claims for defects towards the seller in the relevant country of purchase. In individual countries there may be warranties that can be issued by the relevant dealer (official distributor, Truma Partner). In such cases the warranty can be implemented directly through the dealer from whom the Consumer bought the unit. The warranty regulations of the country in which the unit was purchased by the Consumer for the first time shall also be applicable.

2. Warranty exclusions

No warranty claim shall be applicable under the following circumstances:

- Improper use, contrary to the specified use
- Improper installation, assembly or commissioning, contrary to operating or installation instructions
- Improper operation, contrary to operating or installation instructions, particularly maintenance, care and warning notes
- Instances where repairs, installations or any other procedures have been conducted by non-authorised partners
- Consumable materials and parts which are subject to natural wear and tear
- Installation of replacement, supplementary or accessory parts that are not original Manufacturer's parts and which have thus caused a defect
- Damage arising from foreign substances (e.g. oils, plasticisers in the gas), chemical or electrochemical influences in the water, or cases when the unit has come into contact with unsuitable substances (e.g. chemical products, unsuitable cleaning agents)

- Damage caused by abnormal environmental or unsuitable operating conditions
- Damage caused by force majeure or natural disasters or any other influences not within Truma's responsibility
- Damage resulting from improper transport

3. Making a warranty claim

The warranty must be claimed with an authorised service partner or at the Truma Service Centre. All the relevant addresses and phone numbers can be found at www.truma.com, in the "Service" section.

To ensure a smooth procedure, we should be grateful if you could have the following details ready before contacting us:

- Detailed description of the defect
- Serial number of the unit
- Date of purchase

The authorised service partner or the Truma Service Centre will then specify the further procedure. To avoid transport damage, the affected unit must only be shipped upon prior arrangement with the authorised service partner or the Truma Service Centre.

If the warranty claim is recognised by the Manufacturer, then the transport expenses shall be borne by the same. If no warranty claim is applicable, the Consumer will be notified accordingly and any repair and transport expenses shall then be the Consumer's liability. We must ask you not to send in a unit without prior arrangement.

- D** Bei Störungen wenden Sie sich bitte an das Truma Servicezentrum oder an einen unserer autorisierten Servicepartner (siehe www.truma.com).
- Für eine rasche Bearbeitung halten Sie bitte Gerätetyp und Seriennummer (siehe Typenschild) bereit.
- GB** Should problems occur, please contact the Truma Service Centre or one of our authorised service partners (see www.truma.com).
- In order to avoid delays, please have the unit model and serial number ready (see type plate).
- F** Veuillez vous adresser au centre de SAV Truma ou à un de nos partenaires de SAV agréés en cas de dysfonctionnements (voir www.truma.com).
- Pour un traitement rapide de votre demande, veuillez tenir prêts le type d'appareil et le numéro de série (voir plaque signalétique).
- I** In caso di guasti rivolgersi al centro di assistenza Truma o a un nostro partner di assistenza autorizzato (consultare il sito www.truma.com).
- Affinché la richiesta possa essere elaborata rapidamente, tenere a portata di mano il modello dell'apparecchio e il numero di matricola (vedere targa dati).
- NL** Bij storingen kunt u contact opnemen met het Truma Servicecentrum of met een van onze erkende servicepartners (zie www.truma.com).
- Voor een snelle bediening dient u apparaattype en serienummer (zie typeplaat) gereed te houden.
- DK** Ved fejl kontaktes Trumas serviceafdeling eller en af vores autoriserede servicepartnere (se www.truma.com).
- Sørg for at have oplysninger om apparattype og serienummer (se typeskiltet) klar for hurtig behandling.
- S** Vid fel kontakta Truma servicecenter eller någon av våra auktoriserade servicepartner (se www.truma.com).
- För snabb handläggning bör du ha aggregatets typ och serienummer (se typskylten) till hands.

- E** Las instrucciones de uso y de montaje en su idioma pueden solicitarse al fabricante Truma o al Servicio postventa Truma en su país.
- FIN** Saat käyttö- ja asennusohjeen pyynnöstä omalla kielelläsi valmistajalta (Truma) tai maasi Truma-huoltoon.
- N** Spør om bruks- og monteringsanvisning på norsk hos produsenten Truma eller Trumas serviceavdeling i landet ditt.
- GR** Μπορείτε να ζητήσετε τις οδηγίες χρήσης και τοποθέτησης στη γλώσσα της χώρας σας από τον κατασκευαστή Truma ή από το σέρβις της Truma στη χώρα σας.
- CZ** Návod k použití a montáži si lze v jazyce vaší země vyžádat u výrobce Truma nebo servisu Truma ve vaší zemi.
- SK** Návod na použitie a montáž vo Vašom štátnom jazyku si môžete vyžiadať u výrobcu Truma alebo v servise Truma vo Vašej krajine.
- P** As instruções de utilização e montagem podem ser solicitadas junto do fabricante Truma ou do serviço de assistência da Truma no seu país.
- H** Az Ön nyelvén a használati és beszerelési utasítás a Truma gyártójától vagy az adott ország Truma szerviztől szerezhető be.
- PL** Instrukcję obsługi i montażu we właściwej wersji językowej można otrzymać w firmie Truma lub serwisie firmy Truma znajdującym się w danym kraju.
- SLO** Navodila za uporabo in vgradnjo v vašem jeziku lahko naročite pri proizvajalcu Truma oz. v servisni službi podjetja Truma v vaši državi.
- TR** Dilinizdeki kullanma ve montaj talimatı, üretici Truma'dan veya ülkenizdeki Truma servisinden talep edilebilir.
- RUS** Руководство по эксплуатации и монтажу на Вашем национальном языке можно запросить у изготовителя Truma или в сервисной службе фирмы Truma в Вашей стране.